



ISO9001 Quality Management System Authentication  
CE Authentication



EN630/EN650A series

---

0.4-1.5KW

Series Inverter  
Ver.2.0

# Users' Manual

SHENZHEN ENCOM ELECTRIC TECHNOLOGIES CO.,LTD.

## Foreword

Thank you for purchasing EN630/EN650A series inverter developed and produced by Shenzhen Encom Electric Technologies CO., LTD.

EN630 series mini hi-performance flux vector inverter, adopts advanced control mode to achieve high torque, high precision and wide-range speed regulation drive, and it also supports speed sensorless torque control and PG control torque. It can meet customer all kinds of requirement to universal inverter. EN630 inverter is a organic combination for customer's universal and industrial control purpose and provides practical main-auxiliary frequency provision, run channel frequency binding, PID regulator, simple PLC, spinning traverse, programmable input&output terminal control, pulse frequency provision and inbuilt Modbus, Can bus, Profibus, RS485 and free protocol and other function and platform. It provides high integration solution for most manufacturing and automation customer and EN630 inbuilt input phase loss function, output phase loss function, short circuit to earth grounding function and many other protective function to improve effectively the system reliability and safety.

EN650A series is a mini multi-function permanent magnet synchronous inverter which combined market demand for synchronous motor and its supporting system, built-in unique control algorithm, can achieve high torque, high precision, wide speed range control for permanent magnet synchronous motor and brushless DC motor, supports PG vector and PG vector control, and also supports speed and torque mode switching.

This brochure provides the installation and wiring settings, fault check and methods, maintenance and other relative issues to customer. To make inverter assemble and operate rightly, and use its high performance to best, please read this brochure carefully before installation usage and keep them well to the final users of inverter.

Please contact our office or dealer anywhere at any moment when you have any doubts or special demands in using these inverters, and you can also contact our after service center in our headquarters directly. We will serve you with all our heart.

We reserve our right to notice you if we change contents of this manual.

# Content

<b>1 Safety information and use notice points.....</b>	<b>1</b>
1.1 Safety precautions .....	1
1.2 Application range .....	3
1.3 Use notice points .....	3
<b>2 Inverter Type and Specification .....</b>	<b>5</b>
2.1 Incoming inverter inspect.....	5
2.2 Type explanation .....	5
2.3 Nameplate explanation .....	5
2.4 Inverter type explanation.....	6
2.5 Appearance and parts name explanation.....	6
2.6 Outer size & gross weight .....	6
2.7 Outer size of keypad and its fixing box .....	7
2.8 Product technic index and spec .....	7
<b>3 Installation and wiring.....</b>	<b>11</b>
3.1 Installation ambient .....	11
3.1.1 The demands for installation ambient.....	11
3.1.2 Installation direction and space.....	11
3.2 Parts disassembly and installation.....	12
3.2.1 Keyboard disassembly and installati.....	12
3.2.2 Plastic cover disassembly and installation.....	12
3.3 Wiring notice points .....	12
3.4 Main loop terminal wiring.....	13
3.4.1 Connection between inverter and fitting parts.....	14
3.4.2 Main loop terminal wiring .....	15
3.5 Basic running wiring diagram.....	15
3.6 Control loop collocation and wiring .....	16
3.6.1 Relative location and function for control board terminal and slide Switch.....	16
3.6.2 Descriptions for control board terminal .....	17
3.6.3 Analog input & output terminal wiring .....	20
3.6.4 Communication terminal wiring .....	21
3.7 Installation guidance of anti-interference.....	22
3.7.1 Noise interference restraining .....	22
3.7.2 Field wiring and earth grounding.....	24
3.7.3 Long distance wiring & Leak current and countermeasure.....	25



3.7.4 Installation demand for electromagnetic on-off electronic device.....	25
<b>4 Run and operation explanation for inverter .....</b>	<b>26</b>
4.1 Run of inverter.....	26
4.1.1 Running order channels .....	26
4.1.2 Frequency-provision channel .....	26
4.1.3 Work state .....	27
4.1.4 Run mode .....	27
4.2 Operation and use of key board.....	29
4.2.1 Keypad layout .....	29
4.2.2 Keypad function description .....	30
4.2.3 LED and indicator light.....	31
4.2.4 Key board display status .....	31
4.2.5 User Management Parameters .....	34
4.2.6 Method for operating keypad.....	34
4.3 Inverter electrification .....	37
4.3.1 Check before electrification.....	37
4.3.2 First electrification .....	37
<b>5 Function Parameter Schedule Graph .....</b>	<b>39</b>
5.1 Symbol description.....	39
5.2 Function parameter schedule graph .....	39
<b>6 Troubleshooting.....</b>	<b>84</b>
6.1 Failure and countermeasure .....	84
6.2 Failure record lookup .....	90
6.3 Failure reset .....	91
6.4 Alarm reset .....	91
<b>7 Maintenance.....</b>	<b>92</b>
7.1 Routine maintenance .....	92
7.2 Inspection and replacement of damageable parts .....	92
7.3 Repair guarantee.....	93
7.4 Storage.....	93
<b>Appendix A EN650A Mini multi-function PMSM Inverter .....</b>	<b>94</b>
<b>Appendix B Free-port Communication Protocol.....</b>	<b>132</b>
<b>Appendix C Modbus communication protocol .....</b>	<b>148</b>
<b>Appendix D Braking unit and braking resistance .....</b>	<b>162</b>

# 1 Safety information and use notice points

To make ensure personal & equipment safety, This chapter must be read carefully before the inverter come into use.

## 1.1 Safety precautions

There are three kinds of safety warnings in this manual as below:

Symbol	Symbol description
	It may cause human death, serious injury or heavy property loss with wrong operation.
	It may result body or device damage with wrong and timeless precautions under operation.
 Note	Should pay extra cautions when inverter in use under this symbol



Forbid to cut off the power source directly when inverter under running, acceleration or deceleration status. Power source could cut off when inverter completely in halt and standby status. Otherwise user should be responsible for inverter and device damage and human injury.



- (1) Forbid to connect AC power source to output terminal U, V, W, otherwise it could cause inverter completely damage.
- (2) Forbid to install inverter on flammable objects, otherwise it may cause fire.
- (3) Do not install inverter in a environment with explosive gas, it may cause explosion.
- (4) Bare connection terminal should be insulation treatment after main loop connection, otherwise it may cause electric shock.
- (5) Do not operate inverter with wet hands when inverter power on, otherwise it may cause electric shock.
- (6) Inverter earth terminal should be well grounding connection.
- (7) Do not open the front cover for wiring when inverter power on. Inverter wiring and check must handle after 10 minutes of inverter power off.
- (8) Wiring connection should handle by qualified person and not allow to slip any conductive objects inside inverter, otherwise it may cause a electric shock or inverter damage.
- (9) when inverter stocked for more than 6 months, using voltage regulator to boost voltage up and keep inverter in standby status for 1 hour, otherwise it may cause electric shock and explosion.



- (1) Forbid to connect control terminals except TA, TB, TC to AC 220V/380V signal, otherwise it may cause inverter completely damage.
- (2) Do not install and run inverter when inverter damage or spare part less, otherwise it may cause fire or human injury.
- (3) inverter should install in a place where can accept itself weight, otherwise it may cause inverter drop down or belongings damage.

## 1.2 Application range

(1) This kind of inverter apply to 3 phase ac asynchronous motor only for general industry.

(2) It should handle cautiously and consult with manufacturer when inverter apply to high reliability required equipment which relevant to life, properties and safety device.

(3) This kind of inverter is the general motor control device in industry. When inverter apply to dangerous equipment, safeguard should be considerable in case of inverter failure.

## 1.3 Use notice points

(1) EN630/EN650A series inverter belong to voltage type inverter, and it is normal with up temperature, noise and vibration of motor increasing over power frequency run slightly.

(2) It is required to match inverter with variable frequency motor running at low speed with constant torque for long time. When match inverter with general asynchronous motor running at low speed, it should take measures to make motor heat dissipation or monitoring motor temperature in avoid of motor flash.

(3) It is necessary to take measures in advance for the damage caused for the bad lubrication of the reduction box and wheel gear mechanical devices running at low speed for long time.

(4) It is necessary to assure at first that the use speed range of motor bearings and mechanical devices, also the increasing of motor vibration and noise should be considered, when motor run over rated frequency.

(5) It is necessary to select the suitable brake assembly for hoisting device and big inertia load to make sure the normal work when inverter stripping from power grid for the overcurrent or overvoltage failure.

(6) Inverter start and stop control through terminal or other normal command channel, otherwise it may cause inverter damage via connecting inverter input terminal to big current switch just like contactor direct to start and stop inverter frequently.

(7) It is necessary to make sure inverter cut off from operation without output, when inverter and motor connect through switch components just like contactor etc. Otherwise it will cause inverter damage.

(8) When inverter output frequency within some range, it may meet mechanical resonance point of load device, through setting jump frequency to avoid it.

(9) Checking power supply voltage within allowed working range before usage, otherwise, It need to change voltage or custom special voltage inverter.

(10) When inverter usage site altitude over 1000 meters, Inverter should

decrease current to use, output current decrease about 10% of rated current per 1000 meters increase.

(11) Motor should do insulation check before first usage or reusage after lay aside for long time. Checking method show as Graph 1-1 below with 500V voltage type megohm meter, insulation resistance should not smaller than 5 M $\Omega$ , otherwise inverter maybe damaged.

(12) Forbid inverter output side to assemble capacitor to improve power factor or anti-thunder dependent resistor etc, otherwise it may cause inverter fault trip or component damage show as Graph 1-2.

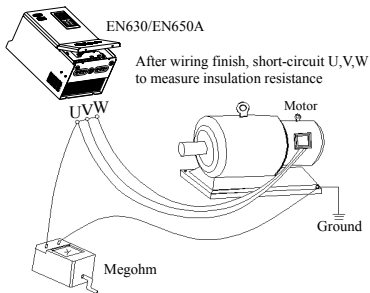

**Fig.1-1 Motor insulation check**

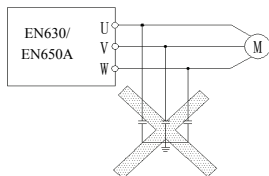

**Fig.1-2 Capacitor at output side forbidden**



## 2 Inverter Type and Specification

### 2.1 Incoming inverter inspect

(1) Check if there is damage during transportation and inverter itself has damage or fall-off parts.

(2) Check if parts presented in packing list are all ready.

(3) Please confirm nameplate data of the inverter is in line with your order requirement.

Our product is guaranteed by strict quality system during manufacturing, packing, Transportation etc., Please contact our company or local agent rapidly if some careless omission or mistake arise, we'll deal with it as soon as possible.

### 2.2 Type explanation

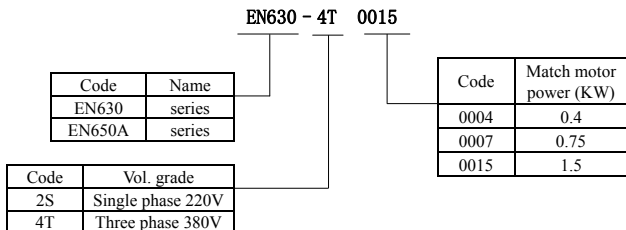

Fig.2-1 Type description

### 2.3 Nameplate explanation

Nameplate presented as Fig.2-2 with type and rating data at the bottom of inverter right side.

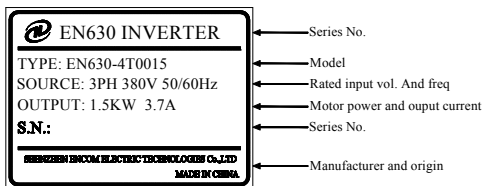

Fig.2-2 Nameplate

## 2.4 Inverter type explanation

Table 2-1 Inverter type explanation

Inverter type	Rated output Current(A)	Adaptable motor (KW)
EN630/EN650A-2S0004	2.5	0.4
EN630/EN650A-2S0007	4	0.75
EN630/EN650A-2S0015	7	1.5
EN630/EN650A-4T0007	2.3	0.75
EN630/EN650A-4T0015	3.7	1.5

## 2.5 Appearance and parts name explanation

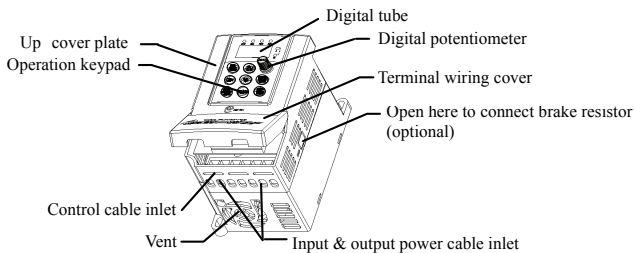

Fig.2-3 Parts name sketch

## 2.6 Outer size & gross weight

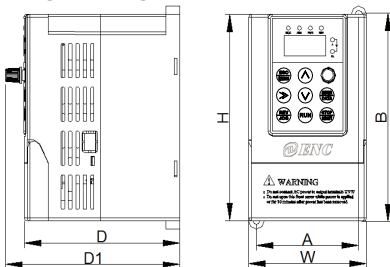

Fig.2-4 Outer dimension

Table 2-2 Mounting size

Inverter type	W (mm)	H (mm)	D (mm)	D1 (mm)	A (mm)	B (mm)	Fix Hole (mm)	GW. (kg)
EN630/EN650A-2S0004	89	148.5	112.5	124.7	74	138	5	1
EN630/EN650A-2S0007								1.1
EN630/EN650A-2S0015								1.2
EN630/EN650A-4T0007								1.1
EN630/EN650A-4T0015								1.1

## 2.7 Outer size of keypad and its fixing box(unit:mm)

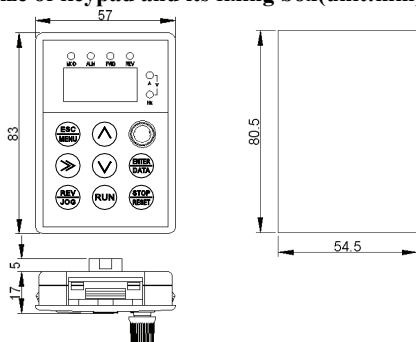

Fig. 2-5 EN-LED5-D keypad&amp; Hole size of keypad

## 2.8 Product technic index and Spec

Item		Item description
Input	Rating volt. frequency	1 phase 220V Grade: single phase 220V, 50Hz/60Hz; 3 phase 380V Grade: 3 phase 380V, 50Hz/60Hz
	Allowed volt range	1 phase 220V Grade: 200~260V; 3 phase 380V Grade: 320~460V
Output	Voltage	0~380V
	Frequency	0~600Hz
	Over loading capacity	150% of rated current for 1 minute

## 2 Inverter Type and Specification

Control Performance	Control mode		Vector control, PG vector control, open-loop V/F control, torque control, PG torque control
	Velocity control precision		±0.5% rated synchronous speed (Vector control); ±0.1% rated synchronous speed (PG vector control); ±1% rated synchronous speed (V/F control).
	Speed regulation range		1: 2000 (PG vector control); 1: 100 (Vector control); 1: 50 (V/F control).
	Start-up torque		1.0Hz: 150% rated torque (V/F control); 0.5Hz: 150% rated torque (Vector control); 0Hz: 180% rated torque (PG vector control).
	Speed fluctuation		±0.3% rated synchronous speed (Vector control); ±0.1% rated synchronous speed (PG vector control).
	Torque control precision		±10% rated torque (Vector control, torque control); ±5% rated torque (PG vector control, PG torque control).
	Torque response		≤20ms (Vector control); ≤10ms (PG vector control);
	Frequency precision		Digital setting: max. frequency×±0.01%; Analog setting: max. frequency×±0.5%
	Freq. resolution	Analog setting	0.1% of max. frequency
		Digital setting precision	0.01Hz
		Exterior impulse	0.1% of max. frequency
	Torque boost		Automatic torque boost; manual torque boost 0.1~12.0%
	V/F curve (Volt. Frequency characteristic)		Setting rated frequency at the range of 5~650Hz, by choosing constant torque, Degressive torque 1, degressive torque 2, Degressive torque 3, self-defined V/F total 5 kinds of curve.
	Acceleration Deceleration curve		Two modes: Straight line acceleration and deceleration; S curve acceleration and deceleration; 15 kinds of acceleration and deceleration time, time unit (0.01s, 0.1s, 1s) for option, Max. time for 1000 minutes.
	Brake	Power consumption brake	Inbuilt brake unit, only add brake resistor between (+) and PB.
		DC Brake	Start, stop action for option, action frequency 0~15Hz, Action current 0~100% of rated current, action time 0~30.0s

## 2 Inverter Type and Specification

	Jog	Jog frequency range: 0Hz ~ up limit frequency; jog acceleration and deceleration time 0.1~6000.0 seconds for setting.
	Multi-section speed run	Realized by inbuilt PLC or control terminal; with 15 section speed, each section speed with separately acceleration and deceleration time; with inbuilt PLC can achieve reserve when power down.
	Inbuilt PID controller	Convenient to make closed-loop control system
	Automatic energy saving run	Optimize V/F curve automatically to achieve power saving run according to the load status.
	Automatic voltage regulate(AVR)	Automatically keep output voltage constant, when the power grid voltage fluctuation
	Automatic current limiting	Current limited automatically under run mode in avoid of inverter over-current frequently to trip.
	Carrier modulation	Modulate carrier wave automatically according to the load characteristic.
	Speed tracking restart	Make rotating motor smoothly start without shocking
Running function	Running command specified channel	Keypad specified, control terminal specified, communication specified can switch through various means.
	Running frequency specified channel	Main & auxiliary specified to a realize one main adjusting and one fine control. Digital specified, analog specified, pulse specified, pulse width specified, communication specified and others, which can be switched by many means at any time.
	Binding function	Run command channel and frequency specified channel can bind together randomly and switch synchronously
Input output characteristic	Digital input channel	Channel 7 for universal digital input, max. Frequency 1KHz, channel 1 can be used as pulse input channel, with max. input 50KHz.
	Analog input channel	Channel 2 for analog input channel, AI1 can choose 4~20mA or 0~10V output, AI2 is differential input channel, 4~20mA or -10~10V for option.
	Pulse output channel	0.1~20KHz pulse square signal output to achieve setting frequency, output frequency and other physical quantity output.
	Analog output channel	Channel 1 for analog signal output, AO can choose 4~20mA or 0~10V to achieve setting frequency, output frequency and other physical quantity output.
Unique function	Rapid current limit	Limit inverter over current to the greatest point, and make it run more stably

## 2 Inverter Type and Specification

	Monopulse control	Suitable for working site where need one button to control inverter start and stop, first press to start, then press to stop, and that cycle repeats. Its very simple and reliable.
	Fixed length control	Realize fixed length control
	Timing control	Timing control function: setting time range 0.1Min ~ 6500.0Min
	Virtual terminal	Five group virtual input & output IO can realize simply logical control
Keypad	Keypad display	The parameters as setting frequency, output frequency, output voltage, output current can be displayed
	Button Locked	Lock all or part of the buttons
Protection function		Motor power on Shot circuit test, input & output phase loss protection, over-current protection, over voltage protection, under voltage protection, over heat protection, overload protection, under load protection, relay absorption protection, terminal protection and no stop protection under power off.
Environment	Application site	Indoor, not bare to sunlight, no dust, no corrosive gas, no flammable gas, no vapor, no water drop or salt etc.
	Altitude	Under 1000 meter. (above 1000 meter require to reduce volume to use, output current reduce about 10% of rated current per 1000 meter high)
	Environment temperature	-10℃ ~ +40℃ (environment temperature between 40℃ ~ 50℃, need to reduce volume or strengthen heat sink)
	Environment humidity	Smaller than 95%RH, no drop condenses
	Vibration	Smaller than 5.9 M/S <sup>2</sup> (0.6g)
	Storage temperature	-40℃ ~ +70℃
Structure	Protection grade	IP20
	Cooling mode	Forced air cooling and natural
Installation mode		Wall hanging



### Note

To get a perfect usage performance of the inverter, Please check and select right type according to this chapter before wiring.



It is necessary to select right type, otherwise it may cause motor abnormal run or inverter damage.

### 3 Installation and wiring

#### 3.1 Installation ambient

##### 3.1.1 The demands for installation ambient

(1) Installed in drafty indoor place, The ambient temperature should be within  $-10^{\circ}\text{C}\sim 40^{\circ}\text{C}$ , It needs external compulsory heat sink or reduce the volume if temperature is over than  $40^{\circ}\text{C}$ .

(2) Avoid installing in places with direct sunlight, much dust, floating fiber and metal powder.

(3) Don't install in place with corrosive, explosive gas.

(4) The humidity should be smaller than 95%RH, Without condensation water.

(5) Installed in place of plane fixing vibration smaller than  $5.9\text{m/s}^2$  (0.6g).

(6) Keep away from electromagnetic disturbance source and other electronic apparatus sensible to electromagnetic disturbance.

##### 3.1.2 Installation direction and space

(1) Normally the inverter should be mounted vertically, horizontal mounting will seriously affect heat dissipation and the inverter must be used in lower volume.

(2) Demand for minimum mounting space and distance, Please see Fig.3-1.

(3) When installing multiple inverters up and down, leading divider must be applied between them, See Fig. 3-2.

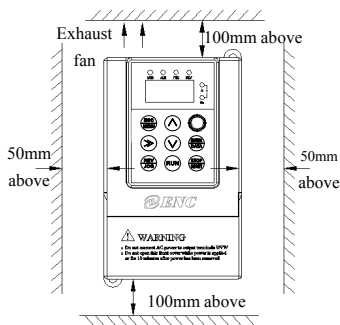

Fig.3-1 Mounting space

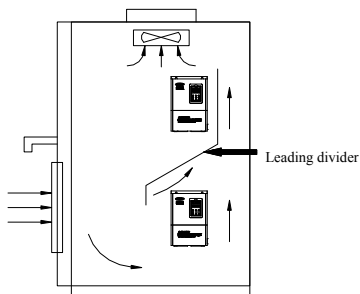

Fig.3-2 Mounting of multiple inverters

## 3.2 Parts disassembly and installation

### 3.2.1 Keyboard disassembly and installation

#### (1) Disassembly

Let the forefinger press finger inlet on the keypad, Press fixing flexible plate on the top lightly, draw it outward, Then you can disassemble the keypad.

#### (2) Assembly

First interface the fixed hook of on the bottom of keyboard with the keyboard installation claw of inverter, Then press the fixed shrapnel on the top of keyboard to push it assemble well properly (Keyboard assemble well when sounding of crisp).

### 3.2.2 Plastic cover disassembly and installation

#### (1) Disassembly

Located the thumbs to the side bayonet, With thumbs press inside and pull upside at the same time until the bayonet open between cover and whole case, Then pull back cover to make it off the inverter.

## 3.3 Wiring notice points



- (1) Assure power be cut off completely for above 10 minutes before wiring, otherwise there is danger of getting electric shock.
- (2) Forbid connecting power wire to output U, V, W of the inverter.
- (3) If there is current leakage inside inverter, when current leakage greater than 5mA for medium & big power inverter, inverter and motor must be earth grounding for safety assurance, and the diameter of earth grounding copper cable is greater than 3.5mm<sup>2</sup>, resistor less than 10Ω.
- (4) Before shipment compression resistance test of the inverter is passed, so users should not conduct compression resistance test again.
- (5) Do not add absorbing capacitor or other resistance-capacitor absorbing device between inverter and motor; also do not add electromagnetic contact, show as Fig.3-3
- (6) To provide inverter over-current protection in output side and convenient maintenance under power off, it should be connected to power source through relay.
- (7) Relay, input & output circuit wiring (X1~X7, Y1, Y2/DO, TA, TB, TC, A11, A12, AO, 485A, 485B) should select greater than 0.75mm<sup>2</sup> stranded wire or shielding wire. One end of the shielding layer hang in the air, and the other end connect to inverter earth grounding terminal, connection wire shorter than 20m.





- (1) Before wiring, assure power supply is cut off completely for 10 minutes and all LED indicator light extinguished.
- (2) Wiring can only be done by professional person trained and qualified.
- (3) Before power on, check if voltage grade of the inverter is in line with that of power supply volt., otherwise will cause personnel injured and device damaged.

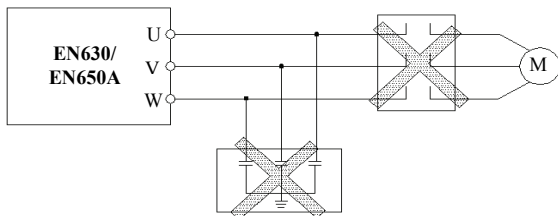

**Fig.3-3** Forbid to use contactor and absorbing capacitor

### 3.4 Main loop terminal wiring



**Fig.3-4** Main loop simple wiring

### 3.4.1 Connection between inverter and fitting parts

(1) Breaking device like isolation Switch must assemble between power source and inverter to keep persona safety under repairing and inverter requirement for compulsory power off.

(2) There must be over-current protection breaker or fuse in inverter power supply circuit to avoid failure expanding because of the second device failure.

(3) AC input reactor

When high harmonics between inverter and power supply is strong which cannot meet system requirement or input side power factor need to improve, ac input reactor can be added.

(4) Contactor is used to power supply only, do not use it to control inverter start and stop.

(5) Input side EMI filter

Optionally EMI filter to restrain high frequency transduction interference and radio-frequency interference from inverter power line.

(6) Output side EMI filter

Choosing optionally EMI filter to restrain radio-frequency Interference and wire leakage current from inverter output side.

(7) AC output reactor

Installing AC output reactor is suggested to avoid motor insulation damage, oversize current leakage and inverter frequent

protection when connecting wire between inverter and motor exceeds 50m. While to consider the voltage decrease issue of AC output rector, it can follow to boost inverter input & output voltage or use smaller power motor to avoid motor damage.

(8) Safety earth ground wire

Inverter and motor must be earth ground connection, connection wire should select as shorter and thicker as above 3.5mm<sup>2</sup> multi-core copper wire, and earth grounding resistance smaller than10Ω.

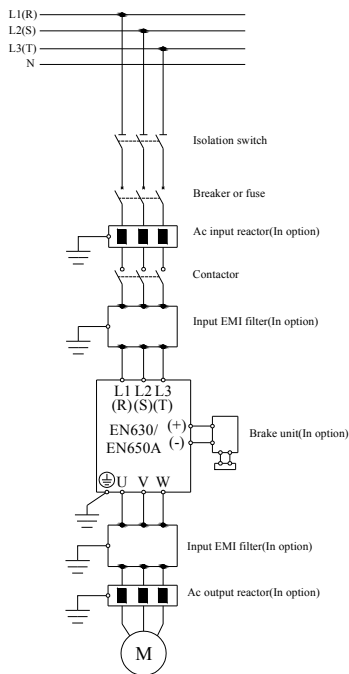
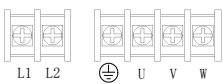

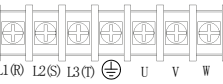



**Fig.3-5 Connection of inverter and fitting parts**

### 3.4.2 Main loop terminal wiring

Main loop input output terminal show as Table 3-1.

**Table 3-1 Main loop input output terminal description**

Adapted type	Main loop terminal	Terminal name	Function description
EN630/EN650A-2S0004 ~ EN630/EN650A-2S0015		L1 L2  U, V, W	Zero line Live line Grounding terminal 3phase AC output terminal
EN630/EN650A-4T0007 ~ EN630/EN650A-4T0015		L1(R), L2(S), L3(T)  U, V, W	3phase AC input terminal Grounding terminal 3phase AC output terminal

### 3.5 Basic running wiring diagram

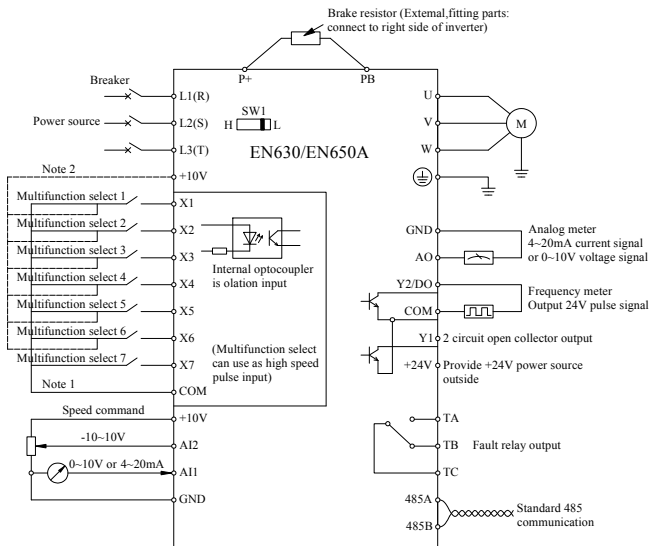

**Fig.3-6 Basic wiring diagram**

Note 1: When X1~X7 terminal input signal low electric level valid , push SW1 to “L” side.

Note 2: When X1~X7 terminal input signal high electric level valid , push SW1 to “H” side.

## 3.6 Control loop collocation and wiring

### 3.6.1 Relative location and function for control board terminal and slide switch:

Control board terminal and slide switch location show as Fig.3-7.

User terminal function explanation can be seen in Table 3-2, The setting description and function of slide switch check Table3-3, Terminal CN3 is for manufacturer usage. Please do the right terminal wiring and setting to the switch on control board before using inverter and it is suggested to use greater than 24 AWG cable to connect terminal.

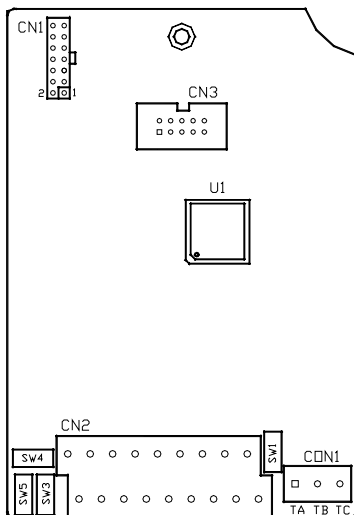

**Fig 3-7 Sketch map of CPU board**

**Table 3-2 Function description of terminal provided for user**

No.	Function	Description
CON1	Fault relay signal output	When inverter alarm failure, the relay open normal switch will close.
CN2	External terminal input & output quantity control	Use the terminal when external terminal to control inverter operate.

**Table 3-3 Slide switch function description for users**

No.	Function	Default
SW4	Analog AO output, 0~10V & 4~20mA switch. Locate “V” side, 0~10V output; locate “I” side, 4~20mA output	0~10V
SW3	Analog AI1 input, 0~10V & 4~20mA switch. Locate “V” side, 0~10V input; locate “I” side, 4~20mA input	0~10V
SW5	Analog AI2 input, -10~10V & 4~20mA switch. Locate “V” side, -10~10V input; locate “I” side, 4~20mA input	-10~10V
SW1	Xi terminal input valid electric level switch: locate “H” side, Xi input high electric level valid(valid voltage range 15~30V); locate “L” side, Xi input low electric level valid(valid voltage range 0~6V)	Low electric level valid

### 3.6.2 Descriptions for control board terminal

(1) CN2 terminal layout as following

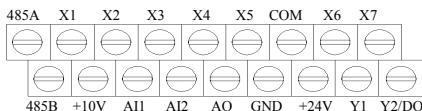

(2) CN2 terminal function description show as Table 3-4

**Table 3-4 Function table for control board terminal**

Type	Symbol	Description	Terminal Function	Specification
Multifunction input terminal	X1	Multifunction input 1	Programmable defined as multifunction switch quantity input terminal, see switch quantity input function parameter (F08 group) input terminal description.	Input impedance: R=2K $\Omega$ Max. input frequency:200Hz X6、 X7 can used as encoder input Max. input frequency:50KHz Input voltage range:15~30V
	X2	Multifunction input 2		
	X3	Multifunction input 3		
	X4	Multifunction input 4		
	X5	Multifunction input 5		
	X6	Multifunction input 6		
	X7	Multifunction input 7/ High-speed pulse input		
	+10V	+10V power source	Provide power source +10V outside(negative polarity: GND)	Max. output current:10mA
	COM	Common terminal +24V power negative polarity	+24V earth	
	GND	+10V power negative polarity	Analog signal and +10V power source reference	
Analog input	AI1	Analog input AI1	Accept analog Voltage/Current quantity input, voltage, current selected by switch SW3, factory default is voltage. (Reference: GND)	Input voltage range: 0~10V (Input impedance: 20K $\Omega$ ) Input current range: 4~20mA (Input impedance: 250 $\Omega$ ) Resolution: 1/4000
	AI2	Analog input AI2	Accept analog voltage quantity input, voltage, current selected by switch SW5.	Input voltage range: -10~10V (Input impedance: 20K $\Omega$ ) resolution: 1/2000
Analog output	AO	Analog output	Provide analog Voltage/Current quantity output, Output Voltage/output current selected by switch SW4, Factory default is output voltage. (Reference: GND)	Current output range: 4~20mA Voltage output range: 0~10V

Multi-function output terminal	+24V	+24V power source	Provide power source +24V outside(negative polarity: COM)	Max. output current:100mA
	Y1	Open circuit collector output terminal 1	Programmable defined as multi-function pulse signal output terminal, particulars see switch quantity, analog quantity function parameter (F09 Group) terminal introduce	Max. output voltage:30V Max. output current:50mA
	Y2/DO	Open circuit collector output terminal 2/ High speed pulse input terminal		Through F00.22 to select terminal output means as open collector output, with same specification as Y terminal, when used to high pulse output: output pulse voltage is 24V, output frequency max. is 20KHz.

(3) RS485 terminal function description show as Table 3-5

**Table 3-5 RS485 terminal function on control board**

Type	Symbol	Description	Terminal Function	Specification
Communication	485A	485 communication interface	485 differential signal positive terminal	Standard 485 communication port should use shielding wire or twisted wire.

(4) Terminal CON1, layout as following:

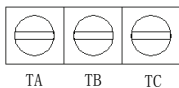

(5) CON1 terminal function description show as Table 3-6

**Table 3-6 CON1 Terminal function on control board**

Type	Symbol	Description	Terminal Function	Specification
Relay output terminal	TA	Fault output relay	Normal: TB-TC close,TA-TC open Alarm: TB-TC open,TA-TC close	TB-TC: Close normal, TA-TC: Open normal. Contactor capacity: AC250V/2A (COSΦ=1) AC250V/1A (COSΦ=0.4) DC30V/1A
	TB			
	TC			

### 3.6.3 Analog input & output terminal wiring

(1) AI1 receive analog voltage signal input, Wire as below:

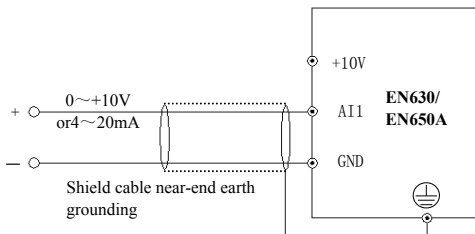

**Fig.3-8 AI1 Terminal wiring diagram**

(2) AI2 receive analog signal input, input voltage (-10~10V) and input current (4~20Ma), wire as below:

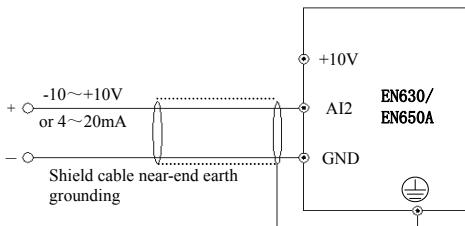

**Fig.3-9 AI2 Terminal wiring diagram**

(3) Analog output terminal AO wire

Analog output terminal AO external connect to analog meter can indicate several physical quantity, wire as below:

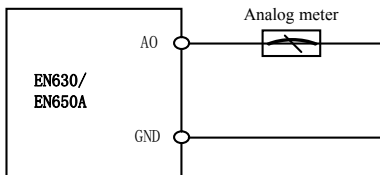

**Fig.3-10 AO Terminal wiring diagram**



**Note**

- (1) Under analog input mode, filter capacitor or common mode choke can be installed between AI1 and GND or AI2 and GND.
- (2) Analog input and output signal can be interfered easily by ambient environment, it need use shield cable for connection and earth grounding well as short as possible.

**3.6.4 Communication terminal wiring**

EN630/EN650A inverter provide RS485 serial communication interface to user.

The following wire connection can make up of single-main single-sub control system or single-main multi-sub control system. To use host computer software (PC or PLC controller) can realize real time monitoring and operation to inverter, and to achieve complicated run control like long-distance control, high degree automation. It can also use one host inverter and others slave inverter to make up of the cascade or synchronous control inverter network.

(1) Inverter RS485 interface and other device with RS485 interface wire connection how as following

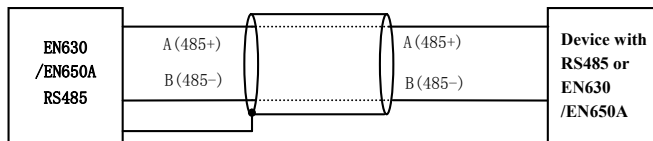
**Fig.3-11 Communication terminal wiring**

(2) Inverter RS485 interface and host computer (Device with RS232 interface) connection:

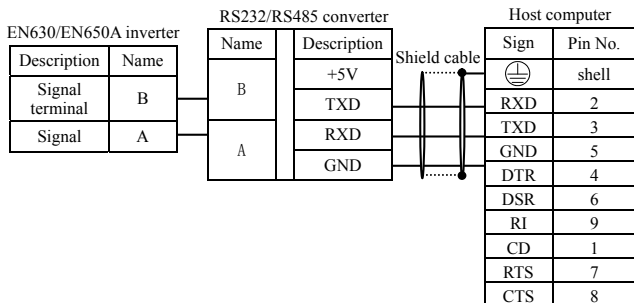
**Fig.3-12 RS485 communication wiring**

### 3.7 Installation guidance of anti-interference

Inverter main circuit consist of high power semiconductor and switch component, For which will generate electromagnetic noise when working, and to avoid or reduce inverter interference to ambient environment, this chapter introduce installation means to restrain interference from aspect of interference restrain, field wiring, system earth grounding, leakage current and power filter usage.

#### 3.7.1 Noise interference restraining

Inverter interference generating for run may have effect to nearby electronic device and the effect depend on the inverter installation surrounding electromagnetic environment and the restrain interference ability of the device.

##### (1) Interference noise type

Because of inverter working principle, there are mainly 3 kinds of noise interference source:

- (1) Circuit conduction interference;
- (2) Space emission interference;
- (3) Electromagnetic induction interference;

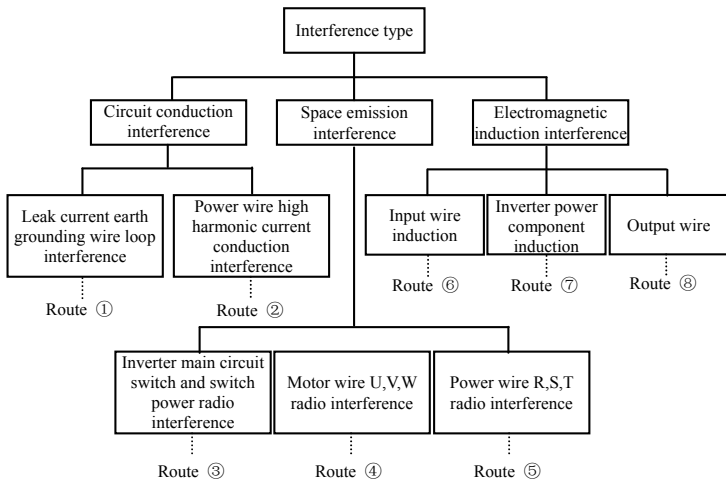

**Fig.3-13 Interference noise type**

## (2) Noise transmission route

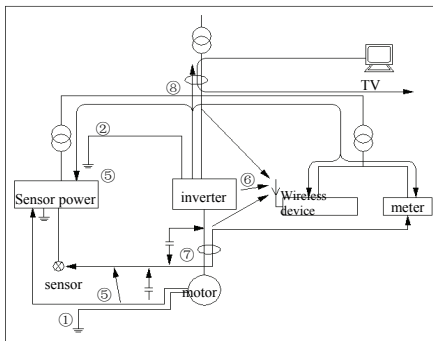

Fig.3-14 Noise interference transmission route diagram

## (3) Basic countermeasure for restrain interference

Table 3-7 Interference restrain countermeasure

Noise spread road	Countermeasure of weakening effect
①	Earth grounding cable of peripheral device and inverter wiring make up of the closed-loop and leakage current of inverter earth grounding cable will make device perform wrong action. It will decrease wrong action when device not connect to earth grounding.
②	When the power of peripheral device and inverter power belong to the same power source, high harmonic generating from inverter will transmit the voltage and current along with the power line which will interfere other devices within the same power source system. Take some restraining measures as below: install electromagnetic noise filter at inverter input end; use isolation transformer to isolate other devices; connect power end of peripheral device to remote power grid; add power ferrite filter magnetic ring to inverter R、S、T three phase wire to restrain high harmonic current conduction
③④⑤	<ul style="list-style-type: none"> <li>● Keep other sensitive devices and signal wire installed away from inverter. it should use shield wire and make the shield layer single end earth grounding. Besides keep distance from inverter and its input &amp; output wire as possible as. When signal wire need to intersect with strong current cable, it should make them orthogonal crossing not parallel.</li> <li>● Install high frequency noise filter (ferrite common code choke, also called magnetic ring) at the bottom end of the inverter input &amp; output to restrain radio</li> </ul>

	<p>frequency interference of dynamic wire effectively.</p> <p>● Motor cable should be placed in protective object with large thickness, such as placed in larger thickness(over 2mm) pipeline or buried in cemented tank. Putting dynamic wire in metal tube and connect to earth grounding with shield wire (motor cable use 4-core cable, one side is earthed through the inverter, the other side connected to motor casing).</p>
<p>⑥⑦⑧</p>	<p>To prevent wire parallel or bundled of strong and weak current, it should keep away from inverter assemble device, and wiring should away from inverter R,S,T,U,V,W power line. Devices with high field and high magnetic field should notice the corresponding installation position of inverter and keep distance and orthogonal crossing.</p>

#### 3.7.2 Field wiring and earth grounding

(1) Inverter terminal motor connection wire (U,V,W terminal output wire) and inverter terminal power connection wire (R,S,T terminal input wire) should keep distance enough as more as 30cm.

(2) U,V,W terminal 3 motor wires should be placed in metal tube or metal wiring tank as possible as.

(3) Generally control signal wire should use shield cable, when shield layer connect to inverter  $\oplus$  terminal, it should be the single end earth grounding which closed to inverter side.

(4) Inverter  $\oplus$  terminal earth grounding cable must directly connect to floor, it cannot connect to earth grounding through other device.

(5) Strong current cable(R,S,T,U,V,W) cannot parallel wiring closely with control signal wire, and bundled together is prohibited. It should keep distance from over 20~60 cm (relative to strong current size). When it's necessary to intersect, it should be orthogonal crossing, show as Fig.3-15.

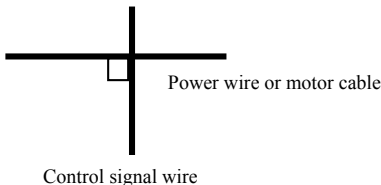

**Fig.3-15 System wiring demand**

(6) Earth grounding wire for strong current should separately connect to earth grounding with control signal and sensor earth grounding wire for weak current.

(7) Forbid to connect inverter input terminal (R,S,T) to other devices.

### 3.7.3 Long distance wiring & Leak current and countermeasure

When inverter connect to motor in a long distance, High harmonic wave through distributed capacitance will generate leak current to earth and wire-to-wire. Restraining methods as below:

- (1) Install ferrite magnetic ring or output reactor at the inverter output terminal.



When reactor installed with rated voltage drop more 5% and long wiring to U, V, W terminal, It would reduce motor's voltage apparently. When motor run at full load, It is possible to flash motor, and it should be used by derating or boosting input and output voltage.

- (2) As carrier frequency low, the motor noise would increase accordingly.

### 3.7.4 Installation demand for electromagnetic on-off electronic device

It should pay attention that surge absorber must be installed when electromagnetic on-off electronic device like relay, electromagnetic contactor and electromagnetic iron generating noise easily and largely installed near to inverter or in the same control cabinet, show as Fig.3-16.

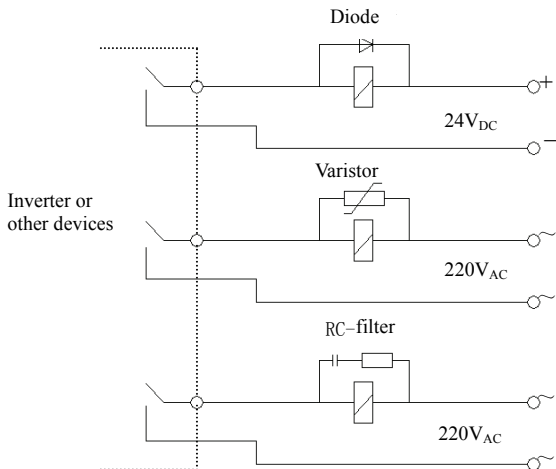

**Fig.3-16** Install demand for electromagnetic on-off device

## 4 Run and operation explanation for inverter

### 4.1 Run of inverter

#### 4.1.1 Running order channels

There are 3 kinds of order channel for controlling run action of the inverter such as run, stop, jog etc.

##### 0:Keypad

Control by key  ,  ,  on keypad (Factory default).

##### 1:Control terminal

Use control terminal Xi (Defined as FWD), Xi (Defined as REV) and COM to make of double-line control, or use anyone terminal of X1 ~ X8 except terminal FWD and REV to make of three-line control.

##### 2:Communication port

Control run and stop of the inverter through upper machine or other device which can communicate with the inverter.

Choose order channel by setting function code F01.15;and also can choose by multi-function input terminal (F08.18~F08.25 choose function 49,50,51,52,53).



Please make switching debugging in advance when switch the order channel to check if it can fulfill system requirement, otherwise have danger of damaging device and injuring personal.

#### 4.1.2 Frequency-provision channel

EN630/EN650A includes main frequency provision and assist frequency provision:

##### Main frequency provision:

0: Keypad analog potentiometer provision;

1: AI1 analog setting;

2: AI2 analog setting;

3: Terminal UP/DOWN adjustment provision;

4: Communication provision (Communication address: 1E01);

5: Reserved;

6: Reserved;

7: High speed pulse provision (X7 terminal need select the corresponding function);

8~14: Reserved

##### Assist frequency provision:

- 0: Keypad analog potentiometer provision;
- 1: AI1 analog setting;
- 2: AI2 analog setting;
- 3: Terminal UP/DOWN adjustment provision;
- 4: Communication provision (Communication address: 1E01);
- 5: Reserved;
- 6: Reserved;
- 7: Terminal pulse provision (X7 terminal need select the corresponding function);
- 8~20: Reserved

### 4.1.3 Work state

Work state of EN630/EN650A includes of Waiting state, Running state and Parameter setting state.

#### **Waiting state :**

If there is no running command after the inverter electrified or after stop command during running state, the inverter enters into waiting state.

#### **Running state:**

The inverter enters into running state after receiving run command.

#### **Parameter setting state:**

After receiving the parameter identification command, enter the parameter setting state, then turning into the shutdown state.

### 4.1.4 Run mode

EN630/EN650A inverter have 6 kinds of run mode, following is in turn according to their priority, Jog run→Closed-loop run→PLC run→Multi-section speed run→Swing frequency run →Common run. Shown as Fig.4-1.

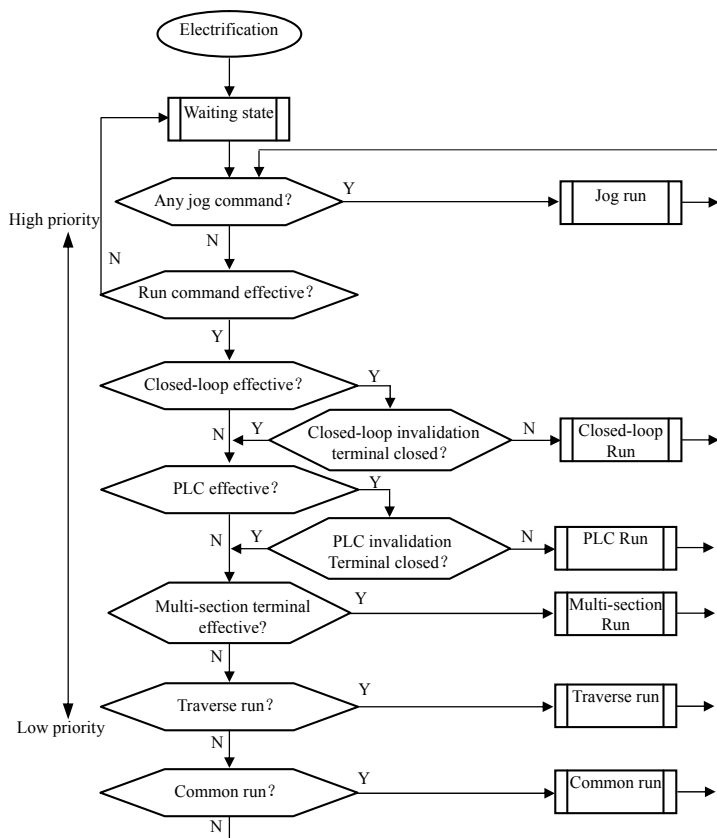



Fig.4-1 Logic flow chart of EN630/EN650A inverter running state



**0:Jog run**

Upon receiving jog run command (For instance, press the  key on keypad) during waiting state, the inverter run at jog frequency (see function code F01.25~F01.29).

**1:Closed-loop run**

The inverter will come into closed-loop run mode when closed-loop run control effective parameter is set (F11.00=1 or F12.00=5). Namely carry on PID adjustment to specified value and feedback value (Proportion integral differential calculation, see F11 Group function code) and PID adjuster output is inverter output frequency. Can make closed-loop run mode ineffective and switch to lower level run mode by multi-function terminal (Function 31).

**2:PLC run**

The inverter will enter into PLC run mode and run according to run mode preset (See F10 Group function code description) through setting PLC function effective parameter(F10.00 last bit≠0). Can make PLC run mode ineffective and switch to lower level run mode by multi-function terminal (function 36).

**3:Multi-section speed run**

By nonzero combination of Multi-function terminal (5, 6, 7, 8, function), choose multi-section frequency 1~15(F10.31~F10.45) to run at multi-section speed.

**4:Swing frequency run**

The inverter will enter into swing frequency run mode when swing frequency function effective parameter (F13.00=1) is set. Set relevant swing frequency run special parameter according to textile swing frequency craft to realize swing frequency run.

**5:Common run**

Common open loop run mode of general inverter.

In above 6 kinds of run mode except “jog run” the inverter can run according to kinds of frequency setting method.

## 4.2 Operation and use of key board

### 4.2.1 Keypad layout

The operating keyboard is the main unit of frequency inverter to accept commands, display parameters. Keyboard outline diagram shown in Fig.4-2.

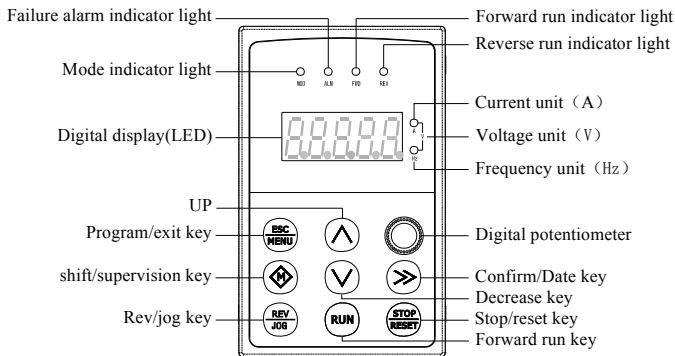



**Fig.4-2 Keypad layout sketch**

### 4.2.2 Keypad function description

There are 8 Key-presses and a digital potentiometer on inverter keypad, and function definition of each key is as shown in Table 4-1.

**Table 4-1 Keypad function table**

Key	Name	Function description
	Program/Exit key	Enter into or exit programming state
	Shift/Supervision key	Can choose modification digit of set data under editor state; can switch display status supervision parameter under other state
	Function/Data key	Enter into or exit programming state
	Rev/Jog key	Under keypad mode: to press this key can set reverse run or Jog run according to the 1 <sup>st</sup> bit of parameter F00.15
	Run key	Enter into forward run under keypad mode
	Stop/reset key	In common run status the inverter will be stopped according to set mode after pressing this key if run command channel is set as keypad stop effective mode. The inverter will be reset and resume normal stop status after pressing this key when the inverter is in malfunction status.

	Digital potentiometer	It is the same as the function of increase and decrease key, rotate to the left means decrease, rotate to the right means increase.
	Increasing button	To increase data or function code (to press it continuously can improve increasing speed)
	Decreasing button	To decrease data or function code (to press it continuously can improve decreasing speed)

### 4.2.3 LED and indicator light

4 status indicator light: They are MOD(mode):ALM(alarm):FWD(forward run):REV(reverse run)from left to right on the LED: Their respective indicating meaning is as shown in Table 4-2.

**Table 4-2 Status indicator light description**

Item		Function description		
Display function	Digital display	Display current run status parameter and set parameter		
	Status indicator light	A、Hz、V	Unit for relevant current digital displayed physical parameter(Forcurrent is A:for voltage is V:for frequency is Hz)	
		MOD	This indicator light is lit in non-supervision status and extinguished if no key pressed for a minute: then come back to supervision status	
		ALM	Alarm indicator light: indicate that the inverter is in over current or over voltage suppressing status or failure alarm status currently	
		FWD	Forward run indicator light, indicate that the inverter output forward phase order and the connected motor rotate in forward direction	The inverter work in DC brake status if FWD,REV indicator light is lit at the same time
		REV	Reverse run indicator light: indicate that the inverter output reverse phase order and the connected motor rotate in reverse direction	

### 4.2.4 Key board display status

EN630/EN650A keypad display status is classified as Waiting status parameter display; Function code parameter editing status display; Malfunction alarm status display; Run status parameter display; Alarm state display in total 5 kinds of status. LED indicator light will all be lit after the inverter electrified. Then enter into set

frequency display. As shown in Fig.4-3 a.

### (1) Waiting parameter display status

The inverter is in waiting status and waiting status supervision parameter is displayed on keyboard: normally parameter F00.13 decide which status supervision parameter to be displayed. As shown in Fig.4-3 b, the indicator light shows the unit of the parameter.

To press  $\gg$  key, It can display different waiting status supervision parameter circularly: For detail please see C-00 to C-05 group supervision parameter details decide by F00.07~F00.12.

### (2) Run parameter display status

The inverter enters into run status when receiving effective run command and normally parameter F00.13 decide which status supervision parameter to be displayed on the keypad. As shown in Fig.4-3 c, The indicator light shows the unit of the parameter.

To press  $\gg$  key can display run status supervision parameter circularly. For detail please see C-00 To C-05 group supervision parameter parameter details decide by F00.01~F00.06 .

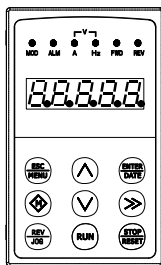

Fig.a Electrification, display 8.8.8.8.8.

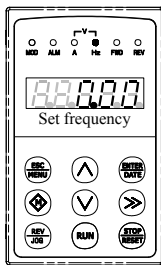

Fig.b Waiting status, display waiting status parameter

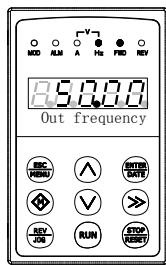

Fig.c Run status: display Run status parameter

**Fig.4-3 Inverter electrification: waiting: run status display**

### (3) Failure alarm display status

The inverter enters into failure alarm display status upon detecting failure signal and display failure code sparkingly(as shown in Fig.4-4);To press  $\langle\langle$  key can look over relative parameter after stopping running;Can press  $\langle$ ESC MENU key to enter into program status to see about F26 group parameter if want to search failure information.Can carry on failure restoration by  $\langle$ STOP RESET key: Control terminal or communication command on the keypad after troubleshooting. Keep displaying failure code if failure exist continuously.

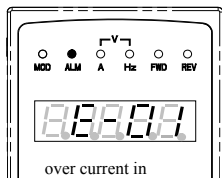

Fig.4-4



For some serious failure, such as inverse module protect, over current: over voltage etc. must not carry on failure reset forcibly to make the inverter run again without failure elimination confirmed. Otherwise have danger of damaging the inverter!

### (4) Function code editing status

Under waiting, run or failure alarm status, press  $\langle$ ESC MENU key, can enter into editing status(If user password is set, can enter into editing status after inputting the password, see also F27.00 description and Fig.4-10), and editing status is displayed according to three classes menu mode, as shown in Fig. 4-5. To press  $\langle$ ENTER/DATA key can enter into one class by one class. Under function parameter display status, press  $\langle$ ENTER/DATA key to carry on parameter storage operation; press  $\langle$ ESC MENU key can only come back to upper class menu without storing modified parameter.

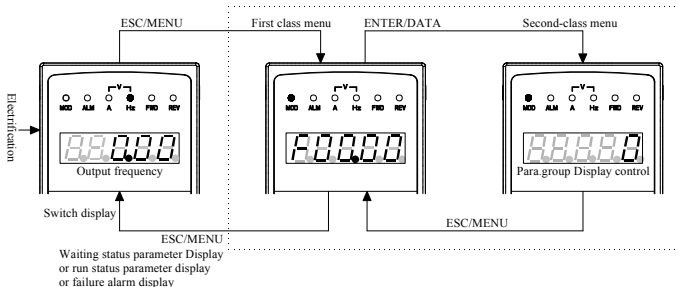

Fig.4-5 Keypad display status switching

### (5) Alarm state display

When under running and standby situation: It means enter failure alarm display status upon detecting failure signal and display failure code sparkingly(Fig.4-6)Inverter keeping running state But this alarm display can not be reset button eliminated: After only find the cause of the alarm: in order to eliminate this factor Normal.

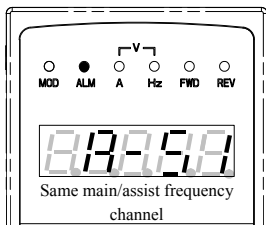

Fig.4-6

### 4.2.5 User Management Parameters

In order to facilitate the user parameter management: EN630/EN650A component model parameter menu for display management. The parameters do not need to be displayed can be shielded.

(1) Method parameter setting mode display.

By setting F00.00 = 0,1,2,3 respectively parameter mode is set: Basic menu mode: menu mode Intermediate: Advanced menu mode and user menu mode.

Basic menu	F00,F01,F02,F03,F26
Middle menu	F00,F01,F02,F03,F04,F05,F06,F07,F08,F09,F10,F11,F12,F13,F14,F15,F16,F18,F19,F26
Advance menu	F00,F01,F02,F03,F04,F05,F06,F07,F08,F09,F10,F11,F12,F13,F14,F15,F16,F17,F18,F19,F20,F21,F22,F23,F24,F25,F26,F27
User custom	F00.00 and F25 parameters group

### 4.2.6 Method for operating keypad

Can carry on various operation to the inverter through keypad, for example:

#### (1) Status parameter display switching:

After pressing key  $\langle \gg \rangle$ , Display C group status supervision parameter; after displaying one supervision parameter code for 1 second will display this parameter value automatically. Press key  $\langle \text{ENTER DATA} \rangle$  will go back to supervision interface.

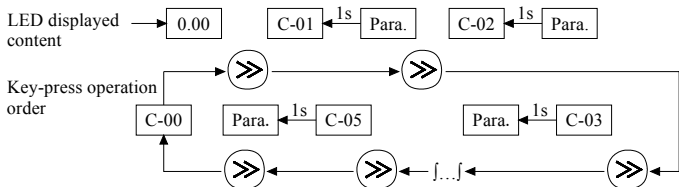

Fig.4-7 Waiting status parameter display operating example

## (2) Function code parameter setting

Take function code F01.01 modified from 5.00Hz to 6.00Hz as example. Boldface in Fig.4-8 shows flickering digit.

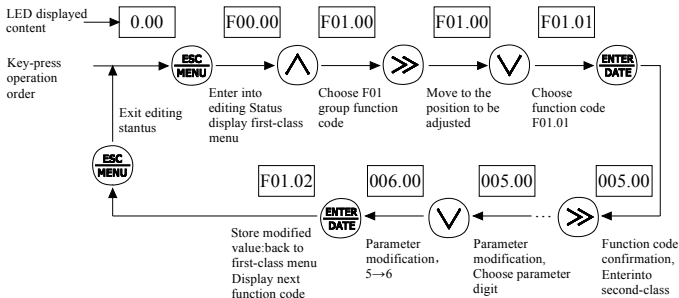

Fig.4-8 Example for parameter setting and modification

Description: under second -class menu: if the parameter has no blinking digit, this function code can't be modified, possible reasons are as follows:

1>This function code shouldn't be modified: for example actual detected status parameter: run record parameter etc.;

2>This function code can't be modified under run status and can be changed after stopping running;

3>Parameter protected. All the function code can't be modified when function code F00.14=1 or 2, In order to avoid wrong operation. Need to set the function code F00.14 to 0 if you want to edit function code parameter.

**(3) Specified frequency adjustment for common run**

Take example modifying specified frequency from 50.00Hz to 40.00Hz at F01.06=1, F01.03=0 during running for explanation.

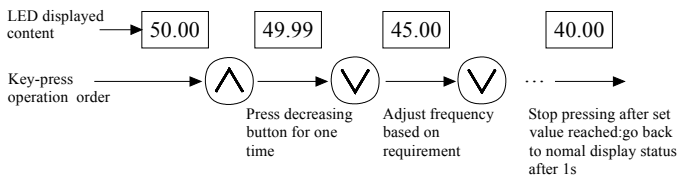

**Fig.4-9 Set frequency adjustment operation example**

**(4) Jog run operation**

For example: keypad as current run command channel: jog run frequency 5Hz: waiting status.

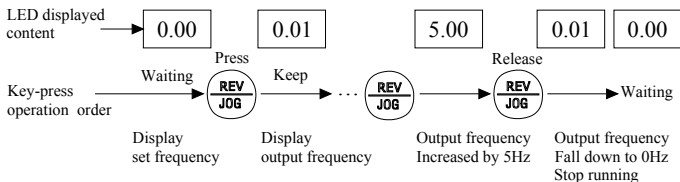

**Fig.4-10 Jog run operating example**

**(5) Operation for entering to function code editing status after setting user password**

For example: "User password" F27.00 is set to "12345". Boldfaced digit in Fig.4-11 shows blinking bit.



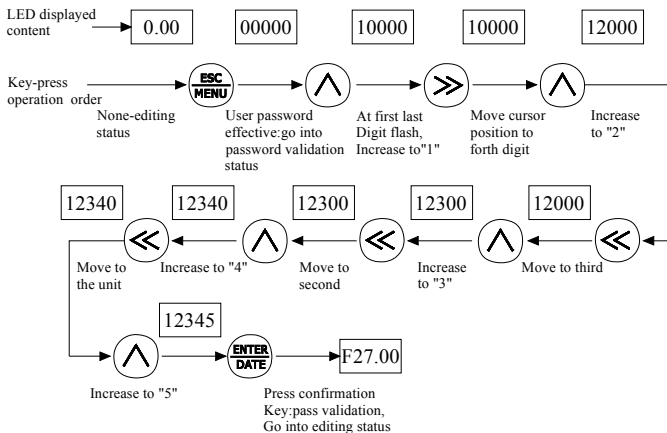

Fig.4-11 Inputting password to go into function code operation

**(6) See about failure parameter under failure status:**

If press  $\gg$  key under failure status the user can quickly locate to the F26 group function code parameter. Press  $\gg$  can quickly switch value between F26.04 ~ F26.10 parameters and fault alarm, easy to view the fault records.

**(7) Keypad key-press locking operation**

Under unlocked keypad situation, press  $\text{ENTER DATA}$  key for 2s to lock the keypad. For detailed operation please refer to 2nd bit of F00.14 function code.

**(8) Keypad key-press unlocking operation**

Under locked keypad situation, press  $\text{ESC MENU}$  key for 5s to unlock the keypad.

## 4.3 Inverter electrification

### 4.3.1 Check before electrification

Please carry on wiring based on operation requirement provided in “inverter wiring” of this Service manual.

### 4.3.2 First electrification

Close input side AC power supply switch after correct wiring and power supply

confirmed: electrify the inverter and keypad LED display “8.8.8.8.8”,

Contactor closed normally: LED displayed set frequency shows that electrification is finished. First electrification operation process is shown as Fig.4-12:

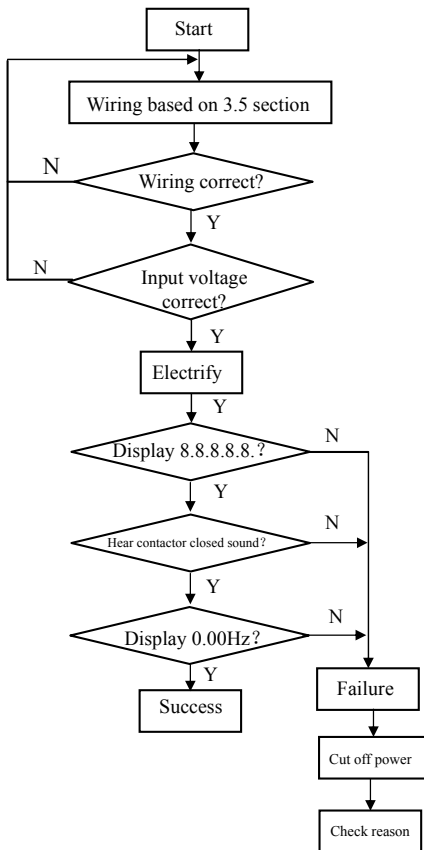

**Fig.4-12 First electrification operation flow**

## 5 Function Parameter Schedule Graph

### 5.1 Symbol description

- × ---- Parameter can't be changed in process of running
- ---- Parameter can be changed in process of running
- \* ---- Read-only parameter, unchangeable

### 5.2 Function parameter schedule graph

F00- System Parameter Group					
Function code	Name	Set range	Min. unit	Factory default	Modification
F00.00	Parameter group display control	0: Basic list mode (Only displayF00~F03 basic control parameter group and F26 fault record parameter group.) 1: Middle list mode. Display all parameter except for extension: Virtual and reserve parameter group. 2: Senior list mode. All parameter display. 3: User list mode. Display parameter defined by user: and monitor parameter: F00.00 display all the time.	1	0	○
F00.01	C-00 display parameter selection when operation	0:Main setup frequency (0.01Hz) 1:Auxiliary setup frequency (0.01Hz) 2:Setup frequency (0.01Hz) 3:Output frequency (0.01Hz) 4:Output current (0.1A) 5:Output voltage (1V) 6:DC bus voltage (0.1V) 7:Motor speed (1 circle/min) 8:Motor line velocity (1 circle/min) 9:Inverter temperature (1℃) 10: Latest working time (0.1min) 11:Current accumulate working time (1h) 12:Current accumulate power-on time (1h) 13:Inverter status 14:Input terminal status 15:Output terminal status 16: Reserve 17: Reserve 18:Communication virtual input terminal status 19:Internal virtual input node status 20:Analog input AI1 (after checkout) (0.01V/0.01mA) 21:Analog input AI2 (after checkout) (0.01V/0.01mA) 22:Reserve	1	3	○













## 5 Function parameter schedule graph

		23:Reserve 24:Analog AO output (after checkout) (0.01V /0.01mA) 25:Reserve 26:Reserve 27:Reserve 28:External pulse input frequency (Before checkout) (1Hz) 29:Reserve 30:Process PID provide (0.01V) 31:Process PID feedback (0.01V) 32:Process PID deviation (0.01V) 33:Process PID output (0.01Hz) 34: Simple PLC current segment No. 35: External multi-speed current segment No. 36:Constant pressure water supply provide pressure (0.001Mpa) 37:Constant pressure water supply feedback pressure (0.001Mpa) 38:Constant pressure water supply relay status 39:Current length (1M) 40:Accumulate length (1M) 41:Current internal count value 42:Current internal time value 43:Run command setup channel (0:Keyboard 1:Terminal 2:Communication) 44:Main frequency provide channel 45:Auxiliary frequency provide channel 46:Rated current (0.1A) 47:Rated voltage (1V) 48:Rated power (0.1KW) 49:Electric torque limit value (0.1% motor specified torque) 50:Braking torque limit value (0.1% motor specified torque) 51:Frequency after add or subtract speed (0.01Hz) 52:Motor rotor frequency (0.01Hz) 53:Current present torque (Relate specified percent of torque, with direction) 54:Current output torque (Relate specified percent of torque, with direction) 55:Torque current at present (0.1A) 56:Flux current at present (0.1A) 57:Setting motor speed (r/min) 58:Output power (Act power) (0.1kw) 59:Total electric cost low-order (1 degree) 60:Total electric cost high-order (1 means 10,000degree) 61-65:Reserve			
F00.02	C-01 display parameter selection	Same as above	1	2	○

## 5 Function parameter schedule graph

	when operation				
F00.03	C-02 display parameter selection when operation	Same as above	1	4	○
F00.03	C-03 display parameter selection when operation	Same as above	1	5	○
F00.05	C-04 display parameter selection when operation	Same as above	1	6	○
F00.06	C-05 display parameter selection when operation	Same as above	1	9	○
F00.07	C-00 display parameter selection when stop	Same as above	1	2	○
F00.08	C-01 display parameter selection when stop	Same as above	1	6	○
F00.09	C-02 display parameter selection when stop	Same as above	1	48	○
F00.10	C-03 display parameter selection when stop	Same as above	1	14	○
F00.11	C-04 display parameter selection when stop	Same as above	1	20	○
F00.12	C-05 display parameter selection when stop	Same as above	1	9	○
F00.13	Power-on fault monitor parameter selection	0~5	1	0	○
F00.14	Parameter operation control	LED units digit: Parameter modification operations 0: All parameters are allowed to be modified 1: Except current parameter, all other parameters are not allowed to modify 2: Except F01.01, F01.04 and current parameter, all other parameters are not allowed to be modified LED tens digit: Reset to factory defaults 0: No action. 1: All parameters return to default. (Not include fault record parameter group (F26 Group) parameter). 2: Except for motor parameter: all parameters return to default. (Not include F15 and F26 group parameter). 3: Extension parameter return to default. (Only	1	000	×

## 5 Function parameter schedule graph

		<p>F21~F24 group parameter return to default).                      4: Virtual parameter return to default.(Only F20 group parameter return to default).                      5:Fault record return to default.(Only fault record parameter group (F26 Group) parameter return to default)                      LED hundreds digit: key operation                      0:All locked                      1:Except  button: the others locked                      2:Except  ,  ,  button: the others locked                      3:Except  ,  button: the others locked.                      4:Except  ,  button: the others locked.</p>			
F00.15	Button function selection	<p>LED units digit: panel  button selection                      0:Reversal command action button                      1:Jog action button                      LED tens digit: Reserve                      LED hundreds digit: terminal run command control                      0:Keyboard  button invalid                      1:Keyboard  button valid                      LED thousands digit: communication run command control                      0:Keyboard  button invalid                      1:Keyboard  button valid</p>	1	0001	○
F00.16	Multi-function key run command channel switching order selection	<p>0: Keyboard control→ Terminal control→ Communication control                      1: Keyboard control←→ Terminal control                      2: Keyboard control←→ Communication control                      3: Terminal control←→communication control</p>	1	0	○
F00.17	Motor speed display coefficient	0.1~999.9%	0.1%	100.0%	○
F00.18	Line speed display coefficient	0.1~999.9%	0.1%	1.0%	○
F00.19	PG card valid selection	<p>0:Invalid                      1:Reserve                      2:Reserve                      3:Incremental PG coder card(F08.24 can't be 91) (Terminal X6, X7 correspond A, B; terminal X5 correspond Z)                      4~10:Reserved</p>	1	0	×
F00.20	Analog input terminal configuration	<p>LED Units digit:All configuration                      0:0~10V input 1:4~20mA input                      LED tens digit: AI2 configuration                      0:-10~10V input 1:4~20mA input                      LED Hundreds digit: Reserve                      LED Thousands digit: Reserve</p>	1	0000	×
F00.21	Analog output terminal	<p>LED units digit: AO configuration                      0:0~10V output</p>	1	0000	×

## 5 Function parameter schedule graph

	configuration	1:4~20mA output LED tens digit: Reserve LED hundreds digit: Reserve LED thousands digit: Reserve			
F00.22	Y output terminal configuration	LED units digit~LED hundreds digit: Reserved LED thousands digit: Y2 output configuration 0:Open collector output 1:DO output	1	0000	×
F00.23	Reserved				
F00.24	Motor control mode	0:V/F control 1: No Speed Vector Control 1(Compare to control 2, It more suit 160kw or less asynchronous motor control, support speed and torque control) 2: Speed sensors vector control (Support asynchronous motor speed and vector control) 3: No Speed sensors vector control 2(Only support asynchronous speed control, more suit 185kw or bigger motor.	1	0	×
F00.25	Monitor parameter 2 selection	Same to F00.01 parameter			
F00.26	Bus bar voltage adjust coefficient	0.900~1.100			
F00.27	Parameters copy	LED units digit: Reserved LED tens digit: Update parameter or download (Digital potentiometer keyboard valid) 0: No action 1: Update 2: Download 1 (No motor parameter) 3: Download 2 (Include motor parameter			

### F01-Basic Run Function Parameter Group

Function code	Name	Set range	Min. unit	Factory default	Modification
F01.00	Main frequency input channel selection	0: Operation keyboard digital setup 1: AI1 analog setup 2: AI2 analog setup 3:Terminal UP/DOWN adjusting setup 4:Communication provide. (Add: 1E01) 5:Reserve 6:Reserve 7:High speed pulse setup X7 terminal need choose the suitable function) 8~14: Reserved	1	0	○
F01.01	Main frequency digital setup	0.00Hz~upper limit frequency	0.01Hz	50.00Hz	○
F01.02	Main frequency digital control	Only when parameter F01.00 = 0, 3, 4 valid. LED units digit: power down reserve setup 0: Main frequency power down reserve. 1: Main frequency power down no reserve.	1	11	○

## 5 Function parameter schedule graph

		LED tens digit: halt reserve setup 0:Halt main frequency hold 1:Halt main frequency recovery F01.01 LED hundreds digit: Communication provide frequency data setup 0:Definit frequency setup (Provide 5,000 means 50.00 Hz) 1:Provide 10,000 means upper limit frequency (F01.11)			
F01.03	Auxiliary frequency input channel select	0: Operation keyboard digital setup 1: A11 analog setup 2: A12 analog setup 3: Terminal UP/DOWN adjusting setup 4: Communication provide. 5: Reserve. 6: Reserve 7: Terminal pulse setup (X7 terminal need choose the suitable function) 8-10: Reserved 11: Process PID provide 12-20: Reserved	1	1	○
F01.04	Auxiliary frequency digital setup	0.00Hz~Upper limit frequency	0.01Hz	0.00Hz	○
F01.05	Auxiliary frequency digital	LED units digit: Power down reserve setup 0: Auxiliary frequency power down reserve. 1: Auxiliary frequency power down no reserve. LED tens digit: Halt reserve setup 0: Halt auxiliary frequency hold. 1: Halt auxiliary frequency recovery parameter F01.04	1	11	○
F01.06	Main and auxiliary provide calculating setup	0: Main frequency (Complex frequency of current is main frequency). 1: Auxiliary frequency (Complex frequency of current is auxiliary frequency.) 2: Plus (Polarity oppose of complex and main frequency, Complex frequency is zero). 3: Minus (Polarity oppose of complex and auxiliary frequency, Complex frequency is zero). 4: Multiplication (Polarity opposed of main and auxiliary frequency: Complex frequency is zero). 5: Max(The max frequency of main and auxiliary absolute value). 6: Min(The min frequency of main and auxiliary absolute value). 7: Selection no-zero value(Auxiliary is not negative, Main frequency prior; Auxiliary is negative, Complex frequency is zero). 8:Main frequency*2/F01.11(Polarity opposed of main frequency: Complex frequency is zero)	1	0	○



## 5 Function parameter schedule graph

F01.07	Auxiliary frequency provide coefficient	0.00~10.00	0.01	1.00	○
F01.08	Coefficient after complex of main and auxiliary frequency	0.00~10.00	0.01	1.00	○
F01.09	Auxiliary frequency range selection	0: Relative upper limit frequency. 1: Relative main frequency.	1	0	○
F01.10	Auxiliary frequency source scope	0.00~1.00	0.01	1.00	○
F01.11	Upper limit frequency	Low limit frequency~600.00Hz	0.01Hz	50.00Hz	×
F01.12	Low limit frequency	0.00Hz~upper limit frequency	0.01Hz	0.00Hz	×
F01.13	Low limit frequency run mode	0: As low limit frequency run. 1: As setting frequency run. 2: As zero frequency run. 3: Sleep: PWM clocked at sleep mode.	1	0	×
F01.14	Sleep run hysteresis frequency	0.01Hz~upper limit frequency (This function can be used to finish the sleep mode function, realizing energy-saving operation process, and the hysteresis width can avoid inverter starting frequently in threshold)	0.01Hz	0.01Hz	○
F01.15	Run command channel selection	0: Operation keyboard run control. 1: Terminal run command control 2: Communication run command control.	1	0	○
F01.16	Run direction setup	LED units digit: Keyboard command For/Rev setup (Only valid to keyboard inching command) 0:Reserve 1:Reverse LED tens digit: For/Rev forbid (Suitable for all command channel, Not include inching function) 0: For/Rev available. 1: Reverse not available (Imposing on reverse, stop as the halt mode). 2:Forward not available (Imposing on forward, Stop as the halt mode) LED hundreds digit: reverse is ok(only suitable for keyboard and communication channel) 0:Invalid 1:Valid LED thousands digit: terminal multi-speed add or minus speed control 0: Respectively correspond 1 to 15 1: Confirm by F01.17&01.18	1	00	○
F01.17	Acceleration time 1	1~60000 (Acceleration time is interval accelerate from zero frequency to upper limit frequency)	1	Base on motor type	○
F01.18	Deceleration time 1	1~60000 (Deceleration time is the interval decelerate from upper limit frequency to zero frequency.)	1	Base on motor type	○

## 5 Function parameter schedule graph

F01.19	Acc/dece time unit	0:0.01s 1:0.1s 2:1s	1	1	×
F01.20	Acc/dece mode selection	0: Line acc/Dece mode. 1: S curve acc/Dece mode.	1	0	×
F01.21	S curve acceleration initiation segment time	10.0%~50.0% (Acceleration/deceleration time) S curve acceleration start time+ S curve acceleration raise time ≤ 90% )	0.1%	20.0%	○
F01.22	S curve acceleration up segment time	10.0%~70.0% (Acceleration/deceleration time) S curve acceleration start time+ S curve acceleration raise time ≤ 90% )	0.1%	60.0%	○
F01.23	S curve deceleration initiation segment time	10.0%~50.0% (Acceleration/deceleration time) S curve deceleration start time+ S curve deceleration raise time ≤90% )	0.1%	20.0%	○
F01.24	S curve deceleration up segment time	10.0%~70.0% (Acceleration/deceleration time) S curve deceleration start time+ S curve deceleration raise time ≤ 90% )	0.1%	60.0%	○
F01.25	Keyboard jog run frequency	0.00Hz~upper limit frequency	0.01Hz	5.00Hz	○
F01.26	Terminal jog run frequency	0.00Hz~upper limit frequency	0.01Hz	5.00Hz	○
F01.27	Terminal jog run frequency	0.0~100.0s	0.1s	0.0s	○
F01.28	Jog acceleration time	0.1~6000.0s	0.1s	20.0s	○
F01.29	Jog deceleration time	0.1~6000.0s	0.1s	20.0s	○

### F02-Start, stop, forward/reverse, brake function parameter group

Function code	Name	Set range	Min. unit	Factory default	Moond ificati
F02.00	Start running mode	0: Start from starting frequency 1: First brake: and then start from starting frequency 2: Start by revolving speed tracking	1	0	×
F02.01	Starting delay time	0.0~60.0s	0.1s	0.0s	×
F02.02	Starting frequency	0.0~10.00Hz	0.01Hz	0.00Hz	×
F02.03	Starting frequency duration	0.0~60.0s	0.1s	0.0s	×
F02.04	Starting braking current when starting	0.0~100.0% (Rated current)	0.1%	30.0%	×
F02.05	Starting braking time when starting	0.0~30.0s	0.1s	0.0s	×
F02.06	Speed track starting frequency selection	0: Current setting frequency. 1: Running frequency before power down. 2: Speed track auxiliary starting frequency.	1	2	×
F02.07	Speed track auxiliary starting frequency	0.00Hz~upper limit frequency	0.01Hz	10.00Hz	×

## 5 Function parameter schedule graph

F02.08	Speed track starting waiting time	0.00~10.00s	0.01s	0.10s	×
F02.09	Speed track current control coefficient	1~20	1	2	×
F02.10	Speed track searching speed time	0.1~30.0s	0.1s	10.0s	×
F02.11	Stop mode	0: Deceleration stop. 1: Free stop 2: Deceleration + DC braking stop.	1	0	×
F02.12	Deceleration stop holding frequency	0.00Hz ~ upper limit frequency (This parameter is only valid for stop mode 0.)	0.01Hz	0.00Hz	×
F02.13	Deceleration stop holding time	0.00~10.00s	0.01s	0.00s	×
F02.14	Stop DC braking starting frequency	0.00~15.00Hz	0.01Hz	0.00Hz	×
F02.15	Stop DC braking waiting time	0.00~30.00s	0.01s	0.00s	×
F02.16	Stop DC braking current	0.0~100.0% (G type inverter rated current)	0.1%	0.0%	×
F02.17	Stop DC braking time	0.0~30.0s	0.1s	0.0s	×
F02.18	Stop auxiliary braking current	0.0~100.0% (G type inverter rated current)	0.1%	0.0%	×
F02.19	Stop auxiliary braking time	0.0~100.0s	0.1s	0.0s	×
F02.20	Forward/reverse dead zone time	0.0~3600.0s	0.1s	0.1s	×
F02.21	Forward/Reverse switching mode	0: Over zero switchover 1: Over starting frequency switchover	1	0	×
F02.22	Energy consumption braking selection	0: No energy consumption braking 1: Energy consumption braking 1 ( No braking if stop working). 2: Energy consumption braking 2 (Can braking if stop working).	1	Base on motor type	○
F02.23	Energy consumption braking voltage	100.0 ~ 145.0% (Rated bus bar voltage )	0.1%	125.0%	○
F02.24	Energy consumption braking use rate	0.0~100.0%	0.1%	50.0%	○
F02.25	Encryption time	0~65535h (When F02.25 data bigger than 1, means valid. VFD power up time (F05.38) longer than F02.25 setup time, Stop working according to decelerate speed way, then keyboard show A-53, can only rework after decode)	1	0	○
F02.26	Over adjusting coefficient	95%~115% (Only F00.24 valid)	1%	100%	○

## F03-V/F control parameter group

Function code	Name	Set range	Min. unit	Factory default	Modification
---------------	------	-----------	-----------	-----------------	--------------

## 5 Function parameter schedule graph

F03.00	V/F curve setting	0:Constant torque curve 1:Degression torque curve 1 (2.0 Power) 2:Degression torque curve 1 (1.7 Power) 3:Degression torque curve 3 (1.2 Power) 4: User self-defined setting V/F curve (Confirmed by F03.04~F03.11) 5: V/F separation control (Voltage channel confirm by F18.22)	1	0	×
F03.01	Torque boost mode	0: Manual boost. 1: Auto torque boost	1	0	○
F03.02	Torque boost	0.0~12.0%	0.1%	Base on motor type	○
F03.03	Torque boost cut-off frequency	0.0~100.0% (Motor rated frequency )	0.1%	20.0%	○
F03.04	V/F frequency value 0	0.00 ~ V/F frequency value 1	0.01Hz	10.00Hz	×
F03.05	V/F voltage value 0	0.00 ~ V/F voltage value 1	0.01%	20.00%	×
F03.06	V/F frequency value 1	V/F frequency value 0 ~ V/F frequency value 2	0.01Hz	20.00Hz	×
F03.07	V/F voltage value 1	V/F voltage value 0 ~ V/F voltage value 2	0.01%	40.00%	×
F03.08	V/F frequency value 2	V/F frequency value 1 ~ V/F frequency value 3	0.01Hz	25.00Hz	×
F03.09	V/F voltage value 2	V/F voltage value 1 ~ V/F voltage value 3	0.01%	50.00%	×
F03.10	V/F frequency value 3	V/F frequency value 2 ~ upper limit frequency	0.01Hz	40.00Hz	×
F03.11	V/F voltage value 3	V/F voltage value 2 ~ 100.00% (Motor rated voltage)	0.01%	80.00%	×
F03.12	V/F oscillation suppression factor	0~255	1	10	○

### F04-Auxiliary running parameter group

Function code	Name	Set range	Min. unit	Factory default	Modification
F04.00	Jump freq. 1	0.00Hz~upper limit frequency	0.01Hz	0.00Hz	×
F04.01	Jump freq. 1 range	0.00Hz~upper limit frequency	0.01Hz	0.00Hz	×
F04.02	Jump freq. 2	0.00Hz~upper limit frequency	0.01Hz	0.00Hz	×
F04.03	Jump freq. 2 range	0.00Hz~upper limit frequency	0.01Hz	0.00Hz	×
F04.04	Jump freq. 3	0.00Hz~upper limit frequency	0.01Hz	0.00Hz	×
F04.05	Jump freq. 3 range	0.00Hz~upper limit frequency	0.01Hz	0.00Hz	×
F04.06	Slip freq. gain	0.0~300.0%	0.1%	0.0%	×
F04.07	Slip compensation limit	0.0~250.0%	0.1%	100.0%	×
F04.08	Slip compensation time constant	0.1~25.0s	0.1s	2.0s	×
F04.09	Carrier freq.	0.5~16.0K	0.1K	Base on motor type	○
F04.10	PWM optimized adjustment	LED units digit: Carrier freq. is adjusted automatically according to temperature 0: Banned. 1: Allowed. LED tens digit: Low speed carrier freq.	1	0110	×

## 5 Function parameter schedule graph

		limit mode 0: No limit. 1: Limit. LED hundreds digit: Carrier wave modulation system 0: 3 phase modulation. 1: 2 phase and 3 phase modulation. LED thousands digit: Asynchronous modulation: synchronization mode (Valid under V/F control) 0: Asynchronous modulation. 1: Synchronous modulation (under 85Hz: Asynchronous modulation).			
F04.11	AVR function	0: No action 1: Action all the time 2: No action only during deceleration	1	0	×
F04.12	Reserved				
F04.13	Auto energy-saving operation	0: No action 1: Action	1	0	×
F04.14	Acceleration time 2 and 1 switchover frequency	0.00Hz~upper limit frequency	0.01Hz	0.00Hz	×
F04.15	Deceleration time 2 and 1 switchover frequency	0.00Hz~upper limit frequency	0.01Hz	0.00Hz	×
F04.16	Acceleration time 2	1~60000	1	200	○
F04.17	Deceleration time 2	1~60000	1	200	○
F04.18	Acceleration time 3	1~60000	1	200	○
F04.19	Deceleration time 3	1~60000	1	200	○
F04.20	Acceleration time 4	1~60000	1	200	○
F04.21	Deceleration time 4	1~60000	1	200	○
F04.22	Acceleration time 5	1~60000	1	200	○
F04.23	Deceleration time 5	1~60000	1	200	○
F04.24	Acceleration time 6	1~60000	1	200	○
F04.25	Acceleration time 6	1~60000	1	200	○
F04.26	Acceleration time 7	1~60000	1	200	○
F04.27	Deceleration time 7	1~60000	1	200	○
F04.28	Acceleration time 8	1~60000	1	200	○
F04.29	Deceleration time 8	1~60000	1	200	○
F04.30	Acceleration time 9	1~60000	1	200	○
F04.31	Deceleration time 9	1~60000	1	200	○
F04.32	Acceleration time 10	1~60000	1	200	○
F04.33	Deceleration time 10	1~60000	1	200	○
F04.34	Acceleration time 11	1~60000	1	200	○
F04.35	Deceleration time 11	1~60000	1	200	○
F04.36	Acceleration time 12	1~60000	1	200	○
F04.37	Deceleration time 12	1~60000	1	200	○
F04.38	Acceleration time 13	1~60000	1	200	○
F04.39	Deceleration time 13	1~60000	1	200	○
F04.40	Acceleration time 14	1~60000	1	200	○
F04.41	Deceleration time 14	1~60000	1	200	○
F04.42	Acceleration time 15	1~60000	1	200	○

## 5 Function parameter schedule graph

F04.43	Deceleration time 15	1~60000	1	200	○
F05-Terminal correlative function parameter group					
Function code	Name	Set range	Min. unit	Factory default	Modification
F05.00	protocol selection	0: Modbus protocol . 1~4: Reserved. 5: Free protocol 1(Can modify all the EN630 function parameter) 6: Free protocol 2(Only can modify part of the EN630 function parameter)	1	0	×
F05.01	Baud rate configuration	LED units digit: Free protocol and Modbus Baud rate selection 0:300BPS                   1:600BPS 2:1200BPS                 3:2400BPS 4:4800BPS                 5:9600BPS 6:19200BPS               7:38400BPS 8:57600BPS               9: 115200BPS LED tens digit: Reserved LED hundreds digit: Reserved	1	005	×
F05.02	Data format	LED units digit: Free protocol and Modbus protocol data format 0:1-8-1 format: No parity: RTU. 1:1-8-1 format: Even parity: RTU. 2:1-8-1 format: Odd parity: RTU. 3:1-7-1 format: No parity: ASCII. 4:1-7-1 format: Even parity: ASCII. 5:1-7-1 format: Odd parity: ASCII. LED tens digit: Reserve LED hundreds digit: Modbus & Free protocol act selection 0: Response main engine order, and feedback 1: Response main engine order, no feedback (Feedback when write parameter) 2: Response main engine order, no feedback (No feedback when write parameter) LED thousands digit: (Communication setup internal storage reserve setup) 0: No save 1: Save		000	×
F05.03	Local address	0~247, Modbus protocol 0 is broadcast address. Broadcast address can only receive and execute upper computer broadcast command, cannot respond to upper computer. The address is 0 when turn to free protocol	1	1	×
F05.04	Communication overtime checkout time	0.0~1000.0s	0.1s	0.0s	○

## 5 Function parameter schedule graph

F05.05	Communication error checkout time	0.0~1000.0s	0.1s	0.0s	○
F05.06	Local response delay time	0~200ms (Modbus effective)	1ms	5ms	○
F05.07	Main & sub inverter communication frequency setting percentage	0~500%	1%	100%	○
F05.08	Communication virtual input terminal enabled	00 ~ FFH Bit0: CX1 virtual input terminal enabled 0:Forbidden 1:Enabled Bit1: CX2 virtual input terminal enabled 0:Forbidden 1:Enabled Bit2: CX3 virtual input terminal enabled 0:Forbidden 1:Enabled Bit3: CX4 virtual input terminal enabled 0:Forbidden 1:Enabled Bit4: CX5 virtual input terminal enabled 0:Forbidden 1:Enabled Bit5: CX6 virtual input terminal enabled 0:Forbidden 1:Enabled Bit6: CX7 virtual input terminal enabled 0:Forbidden 1:Enabled Bit7: CX8 virtual input terminal enabled 0:Forbidden 1:Enabled	1	00H	○
F05.09	Communication virtual input terminal joining node	0: Independent node. 1: Terminal node.	1	0	○
F05.10	Communication virtual terminal CX1 function	0~90	1	0	○
F05.11	Communication virtual terminal CX2 function	0~90	1	0	○
F05.12	Communication virtual terminal CX3 function	0~90	1	0	○
F05.13	Communication virtual terminal CX4 function	0~90	1	0	○
F05.14	Communication virtual terminal CX5 function	0~90	1	0	○
F05.15	Communication virtual terminal CX6 function	0~90	1	0	○
F05.16	Communication virtual terminal CX7 function	0~90	1	0	○
F05.17	Communication virtual terminal CX8 function	0~90	1	0	○
F05.18	Input mapping application parameter 1	F00.00~F26.xx	0.01	25.00	○
F05.19	Input mapping application parameter 2	F00.00~F26.xx	0.01	25.00	○
F05.20	Input mapping application parameter 3	F00.00~F26.xx	0.01	25.00	○
F05.21	Input mapping	F00.00~F26.xx	0.01	25.00	○

## 5 Function parameter schedule graph

	application parameter 4				
F05.22	Input mapping application parameter 5	F00.00~F26.xx	0.01	25.00	○
F05.23	Input mapping application parameter 6	F00.00~F26.xx	0.01	25.00	○
F05.24	Input mapping application parameter 7	F00.00~F26.xx	0.01	25.00	○
F05.25	Input mapping application parameter 8	F00.00~F26.xx	0.01	25.00	○
F05.26	Input mapping application parameter 9	F00.00~F26.xx	0.01	25.00	○
F05.27	Input mapping application parameter 10	F00.00~F26.xx	0.01	25.00	○
F05.28	Setup frequency	Show current setup frequency			
F05.29	Increase& decelerate speed frequency	Show current increase& decelerate speed frequency			
F05.30	Synchronous frequency	current synchronous frequency			
F05.31	Output current	Show current output current			
F05.32	Output voltage	Show current output voltage			
F05.33	Bus bar voltage	Show current bus bar voltage			
F05.34	Loading motor speed	Show current loading motor speed			
F05.35	Set torque	Show set torque (Negative if upper 37367)			
F05.36	Output torque	Show output torque(Negative if upper 32767)			
F05.37	Torque current	Show torque current at present			
F05.38	Total power up time	Show vfd total power up time			
F05.39	Total working time	Show vfd total working time			

### F06- Traverse special function parameter group

Function code	Name	Set range	Min. unit	Factory default	Modification
F06.00	Setting curve selection	LED units digit: All curve selection 0: Curve 1. 1: Curve 2 2: Curve 3 LED tens digit: All curve selection Same as unit's digit. LED hundreds digit: High speed pulse curve selection Same as unit's digit. LED thousands digit: Reserved	1	0000	○
F06.01	Curve 1 min. setting	0.0%~curve 1 inflexion setting	0.1%	0.0%	○
F06.02	Corresponding physical quantity of curve 1 min. setting	0.0~100.0%	0.1%	0.0%	○
F06.03	Curve 1 inflexion setting	Curve 1 min. setting ~ curve 1 Max. setting	0.1%	50.0%	○
F06.04	Corresponding physical quantity of curve 1 inflexion setting	0.0~100.0%	0.1%	50.0%	○
F06.05	Curve 1 Max. setting	Curve 1 inflexion setting ~ 100.0%, 100.0% corresponding to 5V Input AD terminal	0.1%	100.0%	○



## 5 Function parameter schedule graph

F06.06	Corresponding physical quantity of curve 1 Max. setting	0.0~100.0%	0.1%	100.0%	○
F06.07	Curve 2 min. setting	0.0% ~ curve 2 inflexion setting	0.1%	0.0%	○
F06.08	Corresponding physical quantity of curve 2 min. setting	0.0~100.0%	0.1%	0.0%	○
F06.09	Curve 2 inflexion setting	Curve 2 min. setting ~ curve 2 Max. setting	0.1%	50.0%	○
F06.10	Corresponding physical quantity of curve 2 inflexion setting	0.0~100.0%	0.1%	50.0%	○
F06.11	Curve 2 Max. setting	Curve 2 inflexion setting ~ 100.0%	0.1%	100.0%	○
F06.12	Corresponding physical quantity of curve 2 Max. setting	0.0~100.0%	0.1%	100.0%	○
F06.13	Curve 3 min. setting	0.0% ~ curve 3 inflexion 1 setting	0.1%	0.0%	○
F06.14	Corresponding physical quantity of curve 3 min. setting	0.0~100.0%	0.1%	0.0%	○
F06.15	Curve 3 inflexion 1 setting	Curve 3 min. setting ~ curve 3 inflexion 2 setting	0.1%	30.0%	○
F06.16	Corresponding physical quantity of curve 3 inflexion 1 setting	0.0~100.0%	0.1%	30.0%	○
F06.17	Curve 3 inflexion 2 setting	Curve 3 inflexion 1 setting ~ curve 3 Max. setting	0.1%	60.0%	○
F06.18	Corresponding physical quantity of curve 3 inflexion 2 setting	0.0~100.0%	0.1%	60.0%	○
F06.19	Curve 3 Max. setting	Curve 3 inflexion 1 setting ~ 100.0%	0.1%	100.0%	○
F06.20	Corresponding physical quantity of curve 3 Max. setting	0.0~100.0%	0.1%	100.0%	○
F06.21	Curve lower than min. input corresponding selection	LED Units digit: curve 1 setting 0: Corresponds to min. setting corresponding physical quantity. 1: 0.0% of the corresponding physical quantity. LED Tens digit: Curve 2 setting Same as units digit. LED Hundreds digit: Curve 3 setting Same as units digit. LED Thousands digit: Extended curve 1 Same as units digit. LED Ten thousands digit: Extended curve 2 Same as units digit.	1	11111	○

**F07-Analog quantity, Pulse input function parameter group**

Function code	Name	Set range	Min. unit	Factory default	Modification
F07.00	All input filter time	0.000~9.999s	0.001s	0.050s	×
F07.01	All setting gain	0.000~9.999	0.001	1.002	○

## 5 Function parameter schedule graph

F07.02	A11 setting bias	0.0~100.0%	0.1%	0.5%	○
F07.03	A12 input filter time	0.000~9.999s	0.001	0.050s	×
F07.04	A12 setting gain	0.000~9.999	0.001	1.003	○
F07.05	A12 setting bias	0.0~100.0%	0.1%	0.1%	○
F07.06	Analog setting bias polarity	LED units digit: A11 setting bias polarity 0: Positive polarity. 1: Negative polarity. LED tens digit: A12 setting bias polarity 0: Positive polarity. 1: Negative polarity.	1	01	○
F07.07	Pulse input filter time	0.000~9.999s	0.001	0.000s	×
F07.08	Pulse input gain	0.000~9.999	0.001	1.000	○
F07.09	Pulse input Max. frequency	0.01~50.00KHz			
F07.10 ~ F07.13	Reserved				
F07.14	Analog input broke line detection threshold	0.0%~100.0%	0.1%	10.0%	○
F07.15	Analog input broke line detection time	0.0~500.0s	0.1s	3.0s	○
F07.16	Analog input broke line protection option	LED units digit: Broke line detection channel selection 0: Invalid 1: A11 2: A12 LED tens digit: Broke line protection option 0: Stop as stop way 1: Obstacle, free stop 2: keep work	1	10	○
F07.17	Potentiometer torque setup coefficient	0.0~100.0%	0.1%	50.0%	○

### F08-On-off input function parameter group

Function code	Name	Set range	Min. unit	Factory default	Modification
F08.00	Input terminal positive and negative logic setting	0000~FFFF	1	0000	○
F08.01	Input terminal filter time	0.000~1.000s	0.001s	0.000s	○
F08.02	X1 Input terminal closed time	0.00~99.99s	0.01s	0.00s	○
F08.03	X1 Input terminal opened time	0.00~99.99s	0.01s	0.00s	○
F08.04	X2 Input terminal closed time	0.00~99.99s	0.01s	0.00s	○
F08.05	X2 Input terminal opened time	0.00~99.99s	0.01s	0.00s	○
F08.06	X3 Input terminal closed time	0.00~99.99s	0.01s	0.00s	○

## 5 Function parameter schedule graph

F08.07	X3 Input terminal opened time	0.00~99.99s	0.01s	0.00s	○
F08.08	X4 Input terminal closed time	0.00~99.99s	0.01s	0.00s	○
F08.09	X4 Input terminal opened time	0.00~99.99s	0.01s	0.00s	○
F08.10	X5 Input terminal closed time	0.00~99.99s	0.01s	0.00s	○
F08.11	X5 Input terminal opened time	0.00~99.99s	0.01s	0.00s	○
F08.12	X6 Input terminal closed time	0.00~99.99s	0.01s	0.00s	○
F08.13	X6 Input terminal opened time	0.00~99.99s	0.01s	0.00s	○
F08.14	X7 Input terminal closed time	0.00~99.99s	0.01s	0.00s	○
F08.15	X7 Input terminal opened time	0.00~99.99s	0.01s	0.00s	○
F08.16	Reserved				
F08.17	Reserved				
F08.18	Input terminal X1 function selection	0:Leave control terminal unused 1: Forward running FWD terminal 2: Reverse running REV terminal 3: External forward jogging control 4: External reverse jogging control 5: Multi-step speed control terminal 1 6: Multi-step speed control terminal 2 7: Multi-step speed control terminal 3 8: Multi-step speed control terminal 4 9:Acceleration/Deceleration time selection terminal 1 10:Acceleration/Deceleration time selection terminal 2 11:Acceleration/Deceleration time selection terminal 3 12:Acceleration/Deceleration time selection terminal 4 13: Main and auxiliary frequency operational rule selection terminal 1 14: Main and auxiliary frequency operational rule selection terminal 2 15: Main and auxiliary frequency operational rule selection terminal 3 16:Frequency ascending command (UP) 17: Frequency descending command(DOWN) 18:Frequency ascending/Descending frequency resetting 19: Multi-step closed loop terminal 1 20: Multi-step closed loop terminal 2 21: Multi-step closed loop terminal 3 22: External equipment failure input	1	1	×

## 5 Function parameter schedule graph

		<p>23: External interruption input  24: External resetting input  25: Free stop input  26: External stop instruction—Stop according to the stop mode  27: Stop DC braking input command DB  28: Inverter running prohibited—Stop according to the stop mode  29: Acceleration/Deceleration prohibited command  30: Three-wire running control  31: Process PID invalid  32: Process PID stop  33: Process PID integral holding  34: Process PID integral resetting  35: Process PID function negation (Closed loop adjustment feature negation)  36: Simple PLC invalid  37: Simple PLC halted  38: Simple PLC stop state resetting  39: Main frequency switchover to digit (Keypad)  40: Main frequency switchover to AI1  41: Main frequency switchover to AI2  42: Reserved  43: Reserved  44: Main frequency setting channel selection terminal 1  45: Main frequency setting channel selection terminal 2  46: Main frequency setting channel selection terminal 3  47: Main frequency setting channel selection terminal 4  48: Auxiliary frequency reset  49: Command switchover to panel  50: Command switchover to terminal  51: Command switchover to communication  52: Running command Channel selection terminal 1  53: Running command Channel selection terminal 2  50: Forward prohibited command (Stop according to the stop mode: invalid for jogging command)  55: Reverse prohibited command (Stop according to the stop mode: invalid for jogging command)  56: Swinging frequency input  57: Resetting state of swinging frequency  58: Interior counter reset end</p>			
--	--	--	--	--	--

## 5 Function parameter schedule graph

		59:Interior counter input end 60:Internal timer resetting 61:Internal timer triggering 62:Length count input 63:Length reset 64:Reset this operation time 65:Speed/Torque control selection 66~90:Reserved 91:Pulse frequency input (F00.19 can't be 3) (X7 VALID) 92:Pulse width PWM input (X7 VALID) 93~96:Reserved			
F08.19	Input terminal X2 function selection	Same as above	1	2	×
F08.20	Input terminal X3 function selection	Same as above	1	0	×
F08.21	Input terminal X4 function selection	Same as above	1	0	×
F08.22	Input terminal X5 function selection	Same as above	1	0	×
F08.23	Input terminal X6 function selection	Same as above	1	0	×
F08.24	Input terminal X7 function selection	Same as above	1	0	×
F08.25	Reserved				
F08.26	FWD/REV operating mode selection	0: Two-wire control mode 1 1: Two-wire control mode 2 2: Two-wire control mode 3 (Monopulse control mode) 3:Three-wire control mode 1 4:Three-wire control mode 2	1	0	×
F08.27	Set internal count value to setting	0~65535	1	0	○
F08.28	Specify internal count to setting	0~65535	1	0	○
F08.29	Internal timer timing setting	0.1~6000.0s	0.1	60.0s	○
F08.30	Terminal pulse encoder frequency rate	0.01 ~ 10.00Hz (Only be effective by given X1:X2 encoder)	0.01Hz	1.00Hz	○
F08.31	Special function selection	LED units digit: Jog previous selection 0: Top level 1: Lowest level LED tens digit: Keyboard showed parameter setup (Under speed control mode) 0: Show setup frequency 1: Show setup torque			

## F09-Output Terminal Corrective Functions

Function	Name	Set range	Min.	Factory	Modifi
----------	------	-----------	------	---------	--------

## 5 Function parameter schedule graph

code			unit	default	-cation
F09.00	Open collector output terminal Y1 output setup	0:Terminal unused 1:Operation(RUN) 2:CW Run 3:CCW Run 4:DC brake 5:Run prepare finish (Bus bar voltage normal, fault free, no run forbid,Receiver of run command's status) 6:Stop command indication 7:No current detected 8:Overcurrent detected 9:Current1 arrival 10:Current2 arrival 11:No frequency output 12:Frequency arrival signal (FAR) 13:Frequency level detect signal 1 (FDT1) 14:Frequency level detect signal 2 (FDT2) 15:Output frequency arrival upper limit (FHL) 16:Output frequency arrival low limit (FLL) 17:Frequency 1 arrival output 18:Frequency 2 arrival output 19:Overload pre-alarm signal (OL) 20:Undervoltage lockout stop (LU) 21:External fault stop (EXT) 22:Fault 23:Alarm 24:Simple PLC operation 25:Simple PLC section operation finish 26:Simple PLC circle operation finish 27:Simple PLC operation stop 28:Traverse frequency high and low limit 29:Setup length arrival 30:Internal counter final value arrival 31:Internal counter designated value arrival 32:Internal timer arrival--output 0.5s valid signal on arrival 33:Operation stop time finish 34:Operation arrival time finish 35:Setup run time arrival 36:Setup power on time arrival 37:1 <sup>st</sup> pump variable frequency 38:1 <sup>st</sup> pump power frequency 39:Reserved 40:Reserved 41:Communication provision 42:Torque control speed limiting 43:Torque receive output 44:Reserved 45:Holding brake logic 1 (Forward& Reverse process holding brake) 46:Holding brake logic 2 (Forward& Reverse	1	0	×

## 5 Function parameter schedule graph

		process not holding brake) 47: Vfd run 1 (Run with no electric) 48: Analog input brake line signal output 49: X1 terminal close valid 50: X2 terminal close valid 51~60: Reserve			
F09.01	Open collector output terminal Y2 output setup	Same as above	1	0	×
F09.02	Reserved				
F09.03	Reserved				
F09.04	RLY1 output setup	Same as above	1	22	×
F09.05	Frequency arrival (FAR) detection range	0.00~50.00Hz	0.01Hz	5.00Hz	○
F09.06	FDT1 (Frequency level) level	0.00Hz~upper limit frequency	0.01Hz	10.00Hz	○
F09.07	FDT1 lag	0.00~50.00Hz	0.01Hz	1.00Hz	○
F09.08	FDT2 (Frequency level) level	0.00Hz~upper limit frequency	0.01Hz	10.00Hz	○
F09.09	FDT2 lag	0.00~50.00Hz	0.01Hz	1.00Hz	○
F09.10	Zero frequency signal detection value	0.00Hz~upper limit frequency	0.01Hz	0.00Hz	○
F09.11	Zero frequency return difference	0.00Hz~upper limit frequency	0.01Hz	0.00Hz	○
F09.12	Zero-current detection range	0.0~50.0%	0.1%	0.0%	○
F09.13	Zero-current detection time	0.00~60.00s	0.01s	0.1s	○
F09.14	Over-current detection value	0.0~250.0%	0.1%	160.0%	○
F09.15	Over-current detection time	0.00~60.00s	0.01s	0.00s	○
F09.16	Current 1 arrival detection value	0.0~250.0%	0.1%	100.0%	○
F09.17	Current 1 width	0.0~100.0%	0.1%	0.0%	○
F09.18	Current 2 arrival detection value	0.0~250.0%	0.1%	100.0%	○
F09.19	Current 2 width	0.0~100.0%	0.1%	0.0%	○
F09.20	Frequency 1 arrival detection value	0.00Hz~upper limit frequency	0.01Hz	50.00Hz	○
F09.21	Frequency 1 arrival detection width	0.00Hz~upper limit frequency	0.01Hz	0.00Hz	○
F09.22	Frequency 2 arrival detection value	0.00Hz~upper limit frequency	0.01Hz	50.00Hz	○
F09.23	Frequency 2 arrival detection width	0.00Hz~upper limit frequency	0.01Hz	0.00Hz	○
F09.24	Output terminal positive and negative logic setup	0000~FFFF (Extension valid)	1	0000	○

## 5 Function parameter schedule graph

F09.25	Y1 output open delay time	0.000~50.000s	0.001s	0.000s	○
F09.26	Y1 output close delay time	0.000~50.000s	0.001s	0.000s	○
F09.27	Y2 output open delay time	0.000~50.000s	0.001s	0.000s	○
F09.28	Y2 output close delay time	0.000~50.000s	0.001s	0.000s	○
F09.29 ~ F09.32	Reserved				
F09.33	RLY1 output close delay time	0.000~50.000s	0.001s	0.000s	○
F09.34	RLY1 output turn-off delay time	0.000~50.000s	0.001s	0.000s	○
F09.35	Analog output(AO) selection	0:Output frequency before slip compensation (0.00Hz~Upper limit frequency) 1:Output frequency after slip Compensation (0.00Hz~Upper limit Frequency) 2:Setup frequency (0.00Hz~Upper limit frequency) 3:Main setting frequency (0.00Hz~Upper limit frequency) 4:Auxiliary setting frequency (0.00Hz~Upper limit frequency) 5:Output current 1 (0~2×Inverter rated current) 6:Output current 2 (0~3×Motor rated current) 7:Output voltage (0~1.2×Load motor rated voltage) 8:Busbar voltage(0~1.5×Rated bus bar voltage) 9:Motor speed (0~3 Rated speed) 10:PID provision (0.00~10.00V) 11:PID feedback (0.00~10.00V) 12:A11 (0.00~10.00V or 4~20mA) 13:A12 (-10.00~10.00V or 4~20mA) 14:Communication provision 15:Motor rotor speed (0.00Hz~Upper limit frequency) 16:Current setup torque (0~2 Rated torque) 17:Current output torque (0~2 Rated torque) 18:Torque current at present(0~2 rated current) 19:Flux current at present (0~1 Motor rated flux current) 20~25: Reserved	1	0	○
F09.36	Reserved				
F09.37	DO function selection (With Y2 reuse)	Same as above	1	0	○
F09.38	Reserved				
F09.39	Analog output (AO1) filter time	0.0~20.0s	0.1s	0.0s	○



## 5 Function parameter schedule graph

F09.40	Analog output (AO1) gain	0.00~2.00	0.01	1.00	○
F09.41	Analog output (AO1) bias	0.0~100.0%	0.1%	0.0%	○
F09.42 ~ F09.44	Reserved				
F09.45	DO filter time	0.0~20.0s	0.1s	0.0s	○
F09.46	DO output gain	0.00~2.00	0.01	1.00	○
F09.47	DO maximum pulse output frequency	0.1~20.0KHz	0.1KH z	10.0KHz	○
F09.48	Torque achieve output detection time	0.02~200.00s	0.01s	1.00s	○
F09.49	Reserved				
F09.50	Reserved				

## F10-Simple PLC/Multi-speed Function Parameter Group

Function code	Name	Set range	Min. unit	Factory default	Modification
F10.00	Simple PLC run setup	LED units digit: run mode selection 0:Inaction 1:Stop after single cycle 2:Final value keep after single cycle 3:Continuous cycle LED tens digit: Interrupt run restart mode selection 0:Restart from first phase 1:Continuous run from phase frequency at interruption 2:Continuous run from run frequency at interruption LED hundreds digit: PLC run time unit 0:Second 1:Minute LED thousands digit: Power-down memory selection 0:No Memory 1:Phase of reserve power down, frequency power down recording PLC run status: contain power down phase, run frequency, time have run.	1	0000	×
F10.01	Phase 1 setup	000H~E22H LED units digit: Frequency setup 0:Multistage frequency i (i=1~15) 1:Frequency determined by complex frequency of main and auxiliary 2: Reserved LED tens digit: Operation direction selection	1	000	○

## 5 Function parameter schedule graph

		0:Forward 1:Reversal 2:Determine by run command LED hundreds digit: ACC/DEC time selection 0:ACC/DEC time 1 1:ACC/DEC time 2 2:ACC/DEC time 3 3:ACC/DEC time 4 4:ACC/DEC time 5 5:ACC/DEC time 6 6:ACC/DEC time 7 7:ACC/DEC time 8 8:ACC/DEC time 9 9:ACC/DEC time 10 A:ACC/DEC time 11 B:ACC/DEC time 12 C:ACC/DEC time 13 D:ACC/DEC time 14 E:ACC/DEC time 15			
F10.02	Phase 2 setup	000H~E22H	1	000	○
F10.03	Phase 3setup	000H~E22H	1	000	○
F10.04	Phase 4 setup	000H~E22H	1	000	○
F10.05	Phase 5 setup	000H~E22H	1	000	○
F10.06	Phase 6 setup	000H~E22H	1	000	○
F10.07	Phase 7 setup	000H~E22H	1	000	○
F10.08	Phase 8 setup	000H~E22H	1	000	○
F10.09	Phase 9 setup	000H~E22H	1	000	○
F10.10	Phase 10 setup	000H~E22H	1	000	○
F10.11	Phase 11 setup	000H~E22H	1	000	○
F10.12	Phase 12 setup	000H~E22H	1	000	○
F10.13	Phase 13 setup	000H~E22H	1	000	○
F10.14	Phase 14 setup	000H~E22H	1	000	○
F10.15	Phase 15 setup	000H~E22H	1	000	○
F10.16	Phase 1 run time	0~6000.0	0.1	10.0	○
F10.17	Phase 2 run time	0~6000.0	0.1	10.0	○
F10.18	Phase 3 run time	0~6000.0	0.1	10.0	○
F10.19	Phase 4 run time	0~6000.0	0.1	10.0	○
F10.20	Phase 5 run time	0~6000.0	0.1	10.0	○
F10.21	Phase 6 run time	0~6000.0	0.1	10.0	○
F10.22	Phase 7 run time	0~6000.0	0.1	10.0	○
F10.23	Phase 8 run time	0~6000.0	0.1	10.0	○
F10.24	Phase 9 run time	0~6000.0	0.1	10.0	○
F10.25	Phase 10 run time	0~6000.0	0.1	10.0	○
F10.26	Phase 11 run time	0~6000.0	0.1	10.0	○
F10.27	Phase 12 run time	0~6000.0	0.1	10.0	○
F10.28	Phase 13 run time	0~6000.0	0.1	10.0	○
F10.29	Phase 14 run time	0~6000.0	0.1	10.0	○
F10.30	Phase 15 run time	0~6000.0	0.1	10.0	○

F10.31	Multi-section frequency 1	0.00Hz ~Upper limit frequency	0.01Hz	5.00Hz	○
F10.32	Multi-section frequency 2	0.00Hz ~Upper limit frequency	0.01Hz	10.00Hz	○
F10.33	Multi-section frequency 3	0.00Hz ~Upper limit frequency	0.01Hz	20.00Hz	○
F10.34	Multi-section frequency 4	0.00Hz ~Upper limit frequency	0.01Hz	30.00Hz	○
F10.35	Multi-section frequency 5	0.00Hz ~Upper limit frequency	0.01Hz	40.00Hz	○
F10.36	Multi-section frequency 6	0.00Hz ~Upper limit frequency	0.01Hz	45.00Hz	○
F10.37	Multi-section frequency 7	0.00Hz ~Upper limit frequency	0.01Hz	50.00Hz	○
F10.38	Multi-section frequency 8	0.00Hz ~Upper limit frequency	0.01Hz	5.00Hz	○
F10.39	Multi-section frequency 9	0.00Hz ~Upper limit frequency	0.01Hz	10.00Hz	○
F10.40	Multi-section frequency 10	0.00Hz ~Upper limit frequency	0.01Hz	20.00Hz	○
F10.41	Multi-section frequency 11	0.00Hz ~Upper limit frequency	0.01Hz	30.00Hz	○
F10.42	Multi-section frequency 12	0.00Hz ~Upper limit frequency	0.01Hz	40.00Hz	○
F10.43	Multi-section frequency 13	0.00Hz ~Upper limit frequency	0.01Hz	45.00Hz	○
F10.44	Multi-section frequency 14	0.00Hz ~Upper limit frequency	0.01Hz	50.00Hz	○
F10.45	Multi-section frequency 15	0.00Hz ~Upper limit frequency	0.01Hz	50.00Hz	○

F11-close loop PID run function parameter group

Function code	Name	Set range	Min. unit	Factory default	Modification
F11.00	Close loop run control selection	0:PID close loop run control invalid 1:PID close loop run control valid	1	0	×
F11.01	Provide channel selection	0:Digital provide 1:A11 analog provide 2:A12 analog provide 3~4:Reserved 5:Pulse provide 6:Communication provide (Add:1D00) 7~8:Reserved	1	0	○
F11.02	Feedback channel selection	0:A11 analog input 1:A12 analog input 2:EAI1 analog input 3:EAI2 analog input 4:A11+A12 5:A11-A12 6:Min {A11, A12} 7:Max {A11, A12} 8:Pulse input 9:Communication feedback (Add:1DOC, 4000 represent 10.00V)	1	0	○
F11.03	Provide channel filtering time	0.01~50.00s	0.01s	0.20s	×
F11.04	Feedback channel filtering time	0.01~50.00s	0.01s	0.10s	×
F11.05	PID output filtering time	0.00~50.00s	0.01s	0.00s	○
F11.06	Provide digital setup	0.00~10.00V	0.01V	1.00V	○
F11.07	Proportional gain Kp	0.000~9.999	0.001	0.150	○
F11.08	Integral gain Ki	0.000~9.999	0.001	0.150	○
F11.09	Differential gain Kd	0.000~9.999	0.001	0.000	○

## 5 Function parameter schedule graph

F11.10	Sample period T	0.01~1.00s	0.01s	0.10s	○
F11.11	Deviation range	0.0~20.0% correspond to provide value percentage	0.1%	2.0%	○
F11.12	PID differential range	0.00~100.00%	0.01%	0.10%	○
F11.13	Close-loop adjust characteristic	0:Action 1:Reaction	1	0	○
F11.14	Feedback channel plus-minus characteristic	0:Positive characteristic 1:Negetive characteristic	1	0	○
F11.15	PID adjusting upper limit frequency	Low limit frequency~ Upper limit frequency	0.01Hz	50.00Hz	○
F11.16	PID adjusting low limit frequency	Low limit frequency~ Upper limit frequency	0.01Hz	0.00Hz	○
F11.17	Integral adjusting selection	0:When integral arrival separate PID threshold value, stop integral adjusting 1:When integral arrival separate PID threshold value, continue threshold value adjusting	1	0	○
F11.18	Integral separate PID threshold value	0.0~100.0%	0.1%	100.0%	○
F11.19	Close-loop preset frequency	0.00Hz ~upper limit frequency	0.01Hz	0.00Hz	○
F11.20	Close-loop preset frequency keep time	0.0~6000.0s	0.1s	0.0s	○
F11.21	Close-loop output changeover selection	0: Close-loop output minus, Low limit frequency run. 1: Cose-loop output minus, Reverse run (Effect by run direction setting ) 2: Confirmed by run order	1	0	○
F11.22	Close-loop output frequency maximum value	0.00Hz~upper limit frequency	0.01Hz	50.00Hz	○
F11.23	Multi-section close-loop provide 1	0.00~10.00V	0.01V	0.00V	○
F11.24	Multi-section close-loop provide 2	0.00~10.00V	0.01V	0.00V	○
F11.25	Multi-section close-loop provide 3	0.00~10.00V	0.01V	0.00V	○
F11.26	Multi-section close-loop provide 4	0.00~10.00V	0.01V	0.00V	○
F11.27	Multi-section close-loop provide 5	0.00~10.00V	0.01V	0.00V	○
F11.28	Multi-section close-loop provide 6	0.00~10.00V	0.01V	0.00V	○
F11.29	Multi-section close-loop provide 7	0.00~10.00V	0.01V	0.00V	○

### F12-Constant Pressure Water Supply Function Parameter Group

Function code	Name	Set range	Min. unit	Factory default	Modification
F12.00	Constant pressure	0:No constant pressure water supply	1	0	×

## 5 Function parameter schedule graph

	water supply mode selection	1~4: Reserved 5: Choose vfd Y1,Y2 as two pumps time limited rotate work, constant voltage supply water type			
F12.01	Target pressure setup	0.000~long-distance pressure gage range	0.001 Mpa	0.200Mpa	○
F12.02	Sleep frequency minimum value	0.00Hz~Upper limit frequency	0.01Hz	30.00Hz	○
F12.03	Awake pressure Threshold	0.000~long-distance pressure gage range	0.001 Mpa	0.150Mpa	○
F12.04	Sleep delay time	0.0~6000.0s	0.1s	0.0s	○
F12.05	Awake delay time	0.0~6000.0s	0.1s	0.0s	○
F12.06	Long-distance pressure gage range	0.001~9.999Mpa	0.001 Mpa	1.000Mpa	○
F12.07	Allowed aviation of upper limit frequency and low limit frequency: When add or decrease pump	0.1~100.0%	0.1%	1.0%	○
F12.08	Pump switching estimate time	0.2~999.9s	0.1s	5.0s	○
F12.09	Electromagnetism switch converter delay time	0.1~10.0s	0.1s	0.5s	○
F12.10	Automatically switching time interval	0000~65535 minute	1	0	×
F12.11	Wake up pattern selection	0: Wake up according to the F12.03 pressure 1: Wake up as the pressure F12.12*F12.01 calculated	1	0	○
F12.12	Wake up pressure coefficient	0.01~ 0.99	0.01	0.75	○
F12.13	Reserved				
F12.14	Reserved				

## F13- Traverse/ Fixed Length Control Function Parameter Group

Function code	Name	Set range	Min. unit	Factory default	Modification
F13.00	Traverse function enable	0:Traverse invalid 1:Traverse valid	1	0	×
F13.01	Traverse run mode	LED units digit: Enter mode 0:Automatically enter 1:Terminal enter manually LED tens digit: 0:Variable swing 1:Fixed swing LED hundreds digit: Traverse halt start mode selection 0:Restart 1:Start as previous halt record	1	0000	×

## 5 Function parameter schedule graph

		LED thousands digit: traverse status reserve selection 0:No reserve 1:Reserve			
F13.02	Traverse frequency swing value	0.0~50.0%	0.1%	10.0%	○
F13.03	Jump frequency	0.0~50.0%	0.1%	2.0%	○
F13.04	Traverse cycle	0.1~999.9s	0.1s	10.0s	○
F13.05	Triangular wave up time	0.0~98.0% (Traverse cycle)	0.1%	50.0%	○
F13.06	Traverse preset frequency	0.00~400.00Hz	0.01Hz	0.00Hz	○
F13.07	Traverse preset frequency waiting time	0.0~6000.0s	0.1s	0.0s	○
F13.08	Setup length	0~65535 (m/cm/mm)	1m	0m	○
F13.09	Pulse No. of axis per circle	1~10000	1	1	○
F13.10	Axis perimeter	0.01~655.35cm	0.01cm	1000cm	○
F13.11	Length left percent	0.01~100.00%			
F13.12	Length correction coefficient	0.001~10.000	0.001	1.000	○
F13.13	After length arrival: Record length manage	LED units digit: Reserve LED tens digit: Set length units 0: Meter 1: Cm 2: Mm LED hundreds digit: Act after length fulfill 0: Continue working 1: Recycle limit length control LED hundreds digit: Software reset length(can reset by communication) 0: Keep free 1: The current length is cleared 2: The current and total length both cleared	0	1	○
F13.14	When stop: Record length manage	LED units digit: Stop and deal with the current length 0: Auto reset 1: Keep length LED tens digit: Power low down length reserve setup 0: No Reserve 1: Reserved LED hundreds digit: Stop and calculate length 0: Don't calculate 1: Calculate	0	1	○

### F14-Vector Control Parameter Group

Function code	Name	Set range	Min. unit	Factory default	Modification
F14.00	Speed/Torque control selection	0: Speed control 1: Torque control (Valid when F00.24=1 or 2)	1	0	○
F14.01	Speed loop high speed proportional gain	0.1~40.0 (Valid when F00.24=1&2)	0.1	20.0	○

## 5 Function parameter schedule graph

F14.02	Speed loop high speed integral time	0.001~10.000s (Valid when F00.24=1 or 2)	0.001s	0.040s	○
F14.03	Speed loop low speed proportional gain	0.1~80.0 (Valid when F00.24=1 or 2)	0.1s	20.0	○
F14.04	Speed loop low speed integral time	0.001~10.000s (Valid when F00.24=1 or 2)	0.001 Hz	0.020Hz	○
F14.05	Speed loop parameter switchover frequency	0.00Hz~20.00Hz (Valid when F00.24=1 or 2)	0.01Hz	5.00Hz	○
F14.06	Low frequency generate electricity stable coefficient	0~50 (Valid when F00.24=1)	1	25	○
F14.07	Current loop proportional gain	1~500 (Valid when F00.24=1 or 2)	1	70	○
F14.08	Current loop integral time	0.1~100.0ms (Valid when F00.24=1 or 2)	0.1ms	4.0ms	○
F14.09	Forward electric torque current limit value(Reverse brake torque current limit)	0.0~250.0% (Valid when F00.24=1 or 2,3)	0.1%	160.0%	○
F14.10	Forward brake torque current limit value (Reverse electric torque current limit)	0.0~250.0% (Valid when F00.24=1 or 2)	0.1%	160.0%	○
F14.11	Asynchronous motor low flux control coefficient	20.0~100.0% (Valid when F00.24=1 or 2)	0.1%	80.0%	○
F14.12	Asynchronous motor min flux coefficient	10.0~80.0% (Valid when F00.24=2)	0.1%	10.0%	○
F14.13	Setting and limit torque channel selection	LED units digit: Torque setting channel selection 0: Digital setting 1: AI1 analog setting 2: AI2 simulation setting 3: Terminal UP / DOWN adjustment setting 4: Communication setting (Communication address: 1D01) 5: Reserved 6: Reserved 7: High-speed pulse setting (X7 terminal needs to be selected to the corresponding function) 8: Reserved LED Tens digit: Electric torque limit channel selection 0: Digital setting 1: AI1 analog setting 2: AI2 simulation setting 3: Terminal UP/DOWN adjustment setting 4: communication reference (Communication address: 1D01) 5: Reserved 6: Reserved	1	0000	×

## 5 Function parameter schedule graph

		<p>7: High-speed pulse setting (X7 terminal needs to be selected to the corresponding function)</p> <p>8: Reserved</p> <p>LED hundreds digit: Brake torque limit channel selection</p> <p>0: Digital setting</p> <p>1: A11 analog setting</p> <p>2: A12 simulation setting</p> <p>3: Terminal UP / DOWN adjustment setting</p> <p>4: Communication setting (Communication address: 1D01)</p> <p>5: Reserved</p> <p>6: Reserved</p> <p>7: High-speed pulse setting (X7 terminal needs to be selected to the corresponding function)</p> <p>8: Reserved</p> <p>LED thousands digit: Reserved</p> <p>Note: This parameter is valid when F00.24 = 1 or 2.</p>			
F14.14	Torque polarity setting	<p>LED units digit: Torque setting polarity</p> <p>0: Positive</p> <p>1: Negative</p> <p>2: Determined by operation command</p> <p>LED tens digit: Torque compensation polarity</p> <p>0: Same as setting torque direction</p> <p>1: Contrary to the set torque direction</p> <p>LED hundreds digit: F14.21 function is weakened when the motor is stalled</p> <p>0: Invalid</p> <p>1: Effective</p> <p>LED thousands digit: Torque control anti-reversing function</p> <p>0: Invalid</p> <p>1: Enable torque control the anti-reversing function remains active</p> <p>2: Only the start moment there is anti-reversal processing</p> <p>Note: This parameter is valid when F00.24 = 1 or 2.</p>	1	0000	○
F14.15	Torque digital setting value	0.0~200.0% (Valid when F00.24=1&2)	0.1%	0.0%	○
F14.16	Torque control forward speed limit channel selection	<p>0: Digital setting</p> <p>1: A11 analog setting</p> <p>2: A12 simulation setting</p> <p>3: Terminal UP/DOWN adjustment setting</p> <p>4: Communication reference (Communication address: 1D0A)</p> <p>5: Reserved</p> <p>6: Reserved</p> <p>7: High-speed pulse setting (X7 terminal needs to be selected to the corresponding function)</p> <p>8: Reserved</p>	1	0	×



## 5 Function parameter schedule graph

		Note: This parameter is valid when F00.24 = 1 or 2.			
F14.17	Torque control reverse speed limit channel selection	0: Digital setting 1: AI1 analog setting 2: AI2 simulation setting 3: Terminal UP/DOWN adjustment setting 4: communication reference (Communication address: 1D0B) 5: Reserved 6: Reserved 7: High-speed pulse setting (X7 terminal needs to be selected to the corresponding function) 8: Reserved Note: This parameter is valid when F00.24 = 1 or 2.	1	0	×
F14.18	Torque control forward speed limit value	0.00Hz~upper limit frequency(Valid when F00.24 = 1 or 2.)	0.01Hz	50.00Hz	○
F14.19	Torque control reverse speed limit value	0.00Hz~upper limit frequency (Valid when F00.24 = 1 or 2.)	0.01Hz	50.00Hz	○
F14.20	Set the torque acceleration/ deceleration time	0.000~60.000s (Valid when F00.24 = 1 or 2.)	0.001s	0.100s	○
F14.21	Torque compensation	0.0~100.0% (Valid when F00.24 = 1 or 2.)	0.1%	5.0%	○
F14.22	Positive torque gain adjustment coefficient	50.0~150.0% (Valid when F00.24 = 1 or 2.)	0.1%	100.0%	○
F14.23	Negative torque gain adjustment coefficient	50.0~150.0% (Valid when F00.24 = 1 or 2.)	0.1%	100.0%	○
F14.24	Flux brake coefficient	0.0~300.0% (Valid when F00.24 = 1 or 2.)	0.1%	0.0%	○
F14.25	Pre-excitation start time constant	0.1~3.0 (Valid when F00.24 = 1)	0.1	0.5	×
F14.26	Speed loop proportion gain	0.010~6.000 (Valid when F00.24 = 3.)	0.001	0.500	○
F14.27	Speed loop integral time constant	0.010~9.999 (Valid when F00.24 = 3.)	0.001	0.360	○
F14.28	Motor stable coefficient	10~300 (Valid when F00.24 = 3.)	1	100	○
F14.29	Suppresses the oscillation compensation gain	100.0~130.0% (Valid when F00.24 = 3.)	0.1%	100.0%	○
F14.30	Torque compensation cutoff frequency	0.00Hz~Upper limit frequency (Valid when F00.24 = 1 or 2.)	0.01Hz	20.00Hz	○

## F15-Asynchronous Motor Parameter Group

Function code	Name	Set range	Min. unit	Factory default	Modification
F15.00	Reserved				

## 5 Function parameter schedule graph

F15.01	Asynchronous motor rated power	0.1~6553.5KW	0.1KW	Base on motor type	×
F15.02	Asynchronous motor rated voltage	1~690V	1V	Base on motor type	×
F15.03	Asynchronous motor rated current	0.1~6553.5A	0.1A	Base on motor type	×
F15.04	Asynchronous motor rated frequency	0.00~600.00Hz	0.01Hz	Base on motor type	×
F15.05	Asynchronous motor rated speed	0~60000r/min	1r/min	Base on motor type	×
F15.06	Asynchronous motor poles No.	1~7	1	2	×
F15.07	Asynchronous motor stator resistance	0.0000~65.535Ω	0.001Ω	Base on motor type	×
F15.08	Asynchronous motor rotor resistance	0.000~65.535Ω	0.001Ω	Base on motor type	×
F15.09	Asynchronous motor leakage inductance	0.00~655.35mH	0.01mH	Base on motor type	×
F15.10	Asynchronous motor mutual inductance	0.00~6553.5mH	0.01mH	Base on motor type	×
F15.11	Asynchronous motor no load current	0.01~655.35A	0.01A	Base on motor type	×
F15.12 ~ F15.18	Reserved				
F15.19	Motor parameter auto adjustment selection	0: No action 1: Asynchronous motor static self-tuning 2: Asynchronous motor rotation no-load self-tuning 3: Reserved Note: ① Before setting, you need to set the nameplate data correctly ② Motor parameter group can be set according to the type of design automatically Value, can also be manually modified, and self-tuning correction. ③ After modifying the F15.01 parameter, other parameters of the motor will be automatically set to the default value.	1	0	×
F15.20 ~ F15.22	Reserved				

### F16-Reserved Parameter Group 1

Function code	Name	Set range	Min. unit	Factory default	Modification
F16.00	Zero servo energy	0:Zero servo invalid 1:Zero servo valid	1	0	○
F16.01	Coder line number	1~10000	1	1024	○

## 5 Function parameter schedule graph

F16.02	Coder line direction	Unit digit: AB phase sequence 0: Forward direction 1: Reverse direction Tens digit: Reserved	1	00	×
F16.03	Coder frequency demultiplication coefficient	0.001~60.000	0.001	1.000	○
F16.04	Coder smoothing coefficient	5~100	1	15	○
F16.05 ~ F16.13	Reserved				

**F17-Reserved Parameter Group 2**

Function code	Name	Set range	Min. unit	Factory default	Modification
F17.00 ~ F17.20	Reserved				

**F18-Enhance Control Parameter Group**

Function code	Name	Set range	Min. unit	Factory default	Modification
F18.00	Operation panel control frequency binding	0: No binding 1: Operation keyboard digital setup 2: A11 analog setup 3: A12 analog setup 4: Terminal UP/DOWN adjusting setup 5: Communication provide 6: Reserved 7: Reserved 8: High speed pulse setup (X7 terminal need choose the relative function) 9: Reserved 10: Terminal encoder provide(decide by X1,X2) 11~15:Reserved	1	0	○
F18.01	Terminal control frequency binding	Same as above	1	0	○
F18.02	Communication control frequency binding	Same as above	1	0	○
F18.03	Digital frequency integral function selection	LED units digit: Keyboard UP/DW integral control 0: Integral function 1: No integral function LED tens digit: Terminal UP/DW integral control 0: Integral function 1: No integral function	1	00	○

## 5 Function parameter schedule graph

		LED hundreds digit: Keyboard shuttle knob enabled(The shuttle keyboard is valid) 0: In the monitoring interface, the shuttle knob is valid 1: In the monitoring interface, the shuttle knob is invalid LED thousands digit: Keyboard adjustment frequency Classic mode selection 0: Invalid 1: Valid, Adjustment range confirmed by F18.05			
F18.04	Keyboard UP/DW integral rate	0.01~50.00Hz	0.01Hz	0.10Hz	○
F18.05	Keyboard no integral single step's size setup	0.01~10.00Hz	0.01Hz	0.01Hz	○
F18.06	Terminal UP/DW integral rate	0.01~50.00Hz	0.01Hz	0.20Hz	○
F18.07	Terminal no integral single step's size setup	0.01~10.00Hz	0.01Hz	0.10Hz	○
F18.08	Droop control decline frequency	0.00~10.00Hz	0.01Hz	0.00Hz	○
F18.09	Setup accumulate power on time	0~65535h	1	0	○
F18.10	Setup accumulate run time	0~65535h	1	0	○
F18.11	Setup run function enable	0: Invalid 1: Valid	1	0	○
F18.12	Setup run stop time	0.1~6500.0Min	0.1Min	2.0Min	○
F18.13	Currently run arrival time	0.0~6500.0Min	0.1Min	1.0Min	○
F18.14	Keyboard UP/DW selection under monitor mode	0:Keyboard frequency provide value adjusting 1:PID digital provide value adjusting 2~6:Reserved	1	0	○
F18.15	V/F oscillation suppression cutoff frequency	0.00Hz~upper limited frequency	0.01Hz	50.00Hz	○
F18.16	Advanced control selection	LED units digit: Torque closed loop control enabled 0: Torque open loop control 1: Torque closed loop control LED tens digit: Torque limit mode 0: Rated by the drive rated current 1: Rated by motor rated torque LED hundreds digit: Lower than the lower frequency of fast crossing enable 0: Invalid 1: Effective LED thousands digit: Torque control when low torque reference PWM block is enabled	1	0001	○

## 5 Function parameter schedule graph

		0: Invalid 1: Effective Note: This parameter is valid when F00.24 = 1 or 2			
F18.17	Cooling fan control selection	LED units digit: fan control mode 0: Smart fan 1: The inverter has been running after power-on 2: Fan is prohibited, but the temperature is greater than 75 degrees automatically open LED tens digit: adjustable speed fan control mode 0: Intelligent PWM speed control 1: Run at maximum speed	1	00	○
F18.18	No velocity vector slip gain	50~200%	1%	100%	○
F18.19	Total power consumption lower position	0~9999	1 degree	0	○
F18.20	Total power consumption higher position	0~65535(1 represent 10000 degree)	10000 degree	0	○
F18.21	Power consumption calculate coefficient	50.0%~200.0%	0.1%	100.0%	○
F18.22	V/F separation control voltage reference channel	0: Number setting (Determined by 18.23) 1: AI1 analog setting 2: AI2 simulation setting 3: Terminal UP/DOWN adjustment setting 4~6: Reserved 7: High speed pulse setting (X7 terminal need to select the corresponding function) 8: Reserved Note: The maximum value of 0 ~ 8 channels corresponds to the motor rated voltage	1	1	○
F18.23	V/F separation control voltage digital reference channel	0.0%~100%	0.1%	0.0%	○
F18.24	Reserved	30~300%	1%	100%	○

**F19-Protective Relevant Function Parameter Group**

Function code	Name	Set range	Min. unit	Factory default	Modification
F19.00	Power off restart waiting time	0.0~20.0s (0 means no start function)	0.1s	0.0s	×
F19.01	Fault self-recovery times	0~10 (0 means no automatic reset function)	1	0	×
F19.02	Fault self-recovery interval time	0.5~20.0s	0.1s	5.0s	×

## 5 Function parameter schedule graph

F19.03	Motor overload protection action selection	0:Alarm: continuous run 1:Alarm, Stop run as halt mode 2:Fault, Free halt	1	2	×
F19.04	Motor overload protection coefficient	20.0~120.0%(motor rated current)	0.1%	100.0%	×
F19.05	Inverter overload pre-alarm detection selection	0:Detection all the time 1:Detection as constant velocity	1	0	×
F19.06	Inverter overload pre-alarm detection level	20~180% (Inverter rated current)	1%	130%	○
F19.07	Inverter overload pre-alarm delay time	0.0~20.0s	0.1s	5.0s	○
F19.08	Motor under-load alarm detection level	0.0~120.0% (Motor rated current)	0.1%	50.0%	○
F19.09	Motor under-load alarm detection time	0.1~60.0s	0.1s	2.0s	○
F19.10	Motor under-load alarm detection action	LED units digit: detection selection 0:No detection 1:Detection all the time when run 2:Detection only when constant velocity LED tens digit: Action selection 0:Alarm, continuous run 1:Alarm, stop run as halt mode 2:Fault, free halt	1	00	○
F19.11	Input& output phase loss, short circuit detection action	LED units digit: Input phase loss 0:No detection 1:Fault, free halt LED tens digit: Output phase loss 0:No detection 1:Fault, free halt LED hundreds digit: Power-on on earth short circuit protect detection enable 0:No detection 1:Fault, free halt LED thousands digit: Operation on earth short circuit protect detection enable 0:No detection 1:Fault, free halt	1	1111	○
F19.12	Overvoltage stall selection	0:Forbid 1:Allowed	1	1	×
F19.13	Overvoltage stall protection voltage	100~150%	1%	125%	×
F19.14	Automatic current limit level	110~230%, G type rated current	1%	170%	×
F19.15	Frequency decline rate of automatic current limit	0.00~99.99Hz/s	0.01Hz/s	10.00Hz/s	×
F19.16	Automatic current limit action selection	0:Constant velocity invalid 1:Constant velocity valid	1	0	×
F19.17	Reserved				

## 5 Function parameter schedule graph

F19.18	Motor run section selection when instant power off	0:Forbid 1:Allowed	1	0	×
F19.19	Frequency droop rate when instant power off	0.00~99.99Hz/s	0.01Hz/s	10.00Hz/s	×
F19.20	Voltage rebound estimate time when instant power off	0.00~10.00s	0.01s	0.10s	×
F19.21	Action estimate voltage when instant power off	60~100% (Rated bus bar voltage)	1%	80%	×
F19.22	Allowed the longest off time when instant power off	0.30~5.00s	0.01s	2.00s	×
F19.23	Terminal external device fault action selection	0:Alarm, Continuous run 1:Alarm, Stop run as halt mode 2:Fault, Free halt	1	2	×
F19.24	Power on terminal protection selection	0:Invalid 1:Valid	1	1	×
F19.25	Provide lost detection value	0~100%	1%	0%	○
F19.26	Provide lost detection time	0.0~500.0s	0.1s	0.5s	○
F19.27	Feedback lost detection value	0~100%	1%	12%	○
F19.28	Feedback lost detection time	0.0~500.0s	0.1s	0.5s	○
F19.29	Deviation magnitude abnormal detection value	0~100%	1%	50%	○
F19.30	Deviation magnitude abnormal detection time	0.0~500.0s	0.1s	0.5s	○
F19.31	Protection action selection 1	LED units digit: PID provide loss detection act 0:No detection 1:Alarm, Continue run 2:Alarm, Stop run as halt mode 3:Fault, Free halt LED tens digit: PID feedback loss detection act 0:No detection 1:Alarm, Continue run 2:Alarm, Stop run as halt mode 3:Fault, Free halt LED hundreds digit: PID error value abnormal detect action 0:No detection 1:Alarm, Continue run 2:Alarm, Stop run as halt mode 3:Fault, Free halt	1	000	○
F19.32	Protection action	LED units digit: Communication abnormal	1	1200	×

## 5 Function parameter schedule graph

	selection 2	<p>action: Include communication time out and error</p> <p>0:Alarm, continue run 1:Alarm, stop run as halt mode 2:Fault, free halt</p> <p>LED tens digit: E<sup>2</sup>PROM abnormal action selection</p> <p>0:Alarm, continue run 1:Alarm, stop run as halt mode 2:Fault, free halt</p> <p>LED hundreds digit: Contactor abnormal action</p> <p>0:Alarm, Continue run 1:Alarm, Stop run as halt mode 2:Fault, Free halt</p> <p>LED thousands digit: Undervoltage fault indication action selection</p> <p>0:No detection 1:Fault, Free halt</p>			
F19.33	Reserved				
F19.34	Reserved				
F19.35	Fault indication and clock during the period of recovery	<p>LED units digit: Fault indication selection during the period of fault reset automatically</p> <p>0:Action 1:No action</p> <p>LED tens digit: Fault clock function selection: to achieve fault display before power down: etc.</p> <p>0:Forbid 1:Open</p>	1	00	×
F19.36	Continuous run frequency selection when alarm	<p>Match up with protect action</p> <p>0: Run at the frequency setup by now 1: Run at the frequency of upper limit 2: Run at the frequency of low limit 3:Run at the frequency of abnormal for standby</p>	1	0	×
F19.37	Abnormal standby frequency	0.00Hz~upper limit frequency	0.01Hz	10.00Hz	×
F19.38	Coder brake line detect time	0.0~8.0s (No detected at 0)	0.01Hz	10.00Hz	○
F19.39	Over speed (OS) detection value	0.0~120.0% (Corresponding to upper limited frequency)	0.1s	0.0s	○
F19.40	Over speed (OS) detection time	0.00~20.00s (No detected at 0)	0.1%	120.0%	○
F19.41	Speed deviate too large (DEV) detection value	0.0~50.0% (Corresponding to upper limited frequency)	0.01s	0.00s	○
F19.42	Speed deviate too large (DEV) detection time	0.00~20.00s (No detected at 0)	0.1%	10.0%	○
F19.43	Over voltage suppression	0.0~100.0%	0.01s	0.00s	○



	coefficient				
F19.44	Reserved				

<b>F20-Internal Virtual Input Output Node Parameter Group</b>					
<b>Function code</b>	<b>Name</b>	<b>Set range</b>	<b>Min. unit</b>	<b>Factory default</b>	<b>Modification</b>
F20.00	Virtual input VDI1 function selection	0~90	1	0	○
F20.01	Virtual input VDI2 function selection	0~90	1	0	○
F20.02	Virtual input VDI3 function selection	0~90	1	0	○
F20.03	Virtual input VDI4 function selection	0~90	1	0	○
F20.04	Virtual input VDI5 function selection	0~90	1	0	○
F20.05	Virtual output VDO1 function selection	0~60	1	0	○
F20.06	Virtual output VDO2 function selection	0~60	1	0	○
F20.07	Virtual output VDO3 function selection	0~60	1	0	○
F20.08	Virtual output VDO4 function selection	0~60	1	0	○
F20.09	Virtual output VDO5 function selection	0~60	1	0	○
F20.10	Virtual output VDO1 open delay time	0.00~600.00s	0.01s	0.00s	○
F20.11	Virtual output VDO2 open delay time	0.00~600.00s	0.01s	0.00s	○
F20.12	Virtual output VDO3 open delay time	0.00~600.00s	0.01s	0.00s	○
F20.13	Virtual output VDO4 open delay time	0.00~600.00s	0.01s	0.00s	○
F20.14	Virtual output VDO1 open delay time	0.00~600.00s	0.01s	0.00s	○
F20.15	Virtual output VDO1 close delay time	0.00~600.00s	0.01s	0.00s	○
F20.16	Virtual output VDO2 close delay time	0.00~600.00s	0.01s	0.00s	○
F20.17	Virtual output VDO3 close delay time	0.00~600.00s	0.01s	0.00s	○
F20.18	Virtual output VDO4 close delay time	0.00~600.00s	0.01s	0.00s	○
F20.19	Virtual output VDO5 close delay time	0.00~600.00s	0.01s	0.00s	○
F20.20	Virtual input VDI enable control	00~FF	1	00	○
F20.21	Virtual input VDI status	00~FF	1	00	○

## 5 Function parameter schedule graph

	digital setup				
F20.22	Virtual input: output connection	00~FF Bit0:VDI1 and VDO1 connection 0: Positive logic 1: Negative logic Bit1:VDI2 and VDO2 connection 0: Positive logic 1: Negative logic Bit3:VDI3 and VDO3 connection 0: Positive logic 1: Negative logic Bit4:VDI4 and VDO4 connection 0: Positive logic 1: Negative logic Bit4:VDI5 and VDO5 connection 0: Positive logic 1: Negative logic	1	00	○

### F21-Reserved Parameter Group 3

Function code	Name	Set range	Min. unit	Factory default	Modification
F21.00 ~ F21.21	Reserved				

### F22-Reserved Parameter Group 4

Function code	Name	Set range	Min. unit	Factory default	Modification
F22.00 ~ F22.17	Reserved				

### F23-Reserved Parameter Group 5

Function code	Name	Set range	Min. unit	Factory default	Modification
F23.00 ~ F23.17	Reserved				

### F24-Reserved Parameter Group 6

Function code	Name	Set range	Min. unit	Factory default	Modification
F24.00 ~ F24.13	Reserved				

### F25-User Definition Display Parameter Group

Function code	Name	Set range	Min. unit	Factory default	Modification
F25.00	User function code 1	F00.00~F25.xx	0.01	25.00	○
F25.01	User function code 2	F00.00~F25.xx	0.01	25.00	○

## 5 Function parameter schedule graph

F25.02	User function code 3	F00.00~F25.xx	0.01	25.00	○
F25.03	User function code 4	F00.00~F25.xx	0.01	25.00	○
F25.04	User function code 5	F00.00~F25.xx	0.01	25.00	○
F25.05	User function code 6	F00.00~F25.xx	0.01	25.00	○
F25.06	User function code 7	F00.00~F25.xx	0.01	25.00	○
F25.07	User function code 8	F00.00~F25.xx	0.01	25.00	○
F25.08	User function code 9	F00.00~F25.xx	0.01	25.00	○
F25.09	User function code 10	F00.00~F25.xx	0.01	25.00	○
F25.10	User function code 11	F00.00~F25.xx	0.01	25.00	○
F25.11	User function code 12	F00.00~F25.xx	0.01	25.00	○
F25.12	User function code 13	F00.00~F25.xx	0.01	25.00	○
F25.13	User function code 14	F00.00~F25.xx	0.01	25.00	○
F25.14	User function code 15	F00.00~F25.xx	0.01	25.00	○
F25.15	User function code 16	F00.00~F25.xx	0.01	25.00	○
F25.16	User function code 17	F00.00~F25.xx	0.01	25.00	○
F25.17	User function code 18	F00.00~F25.xx	0.01	25.00	○
F25.18	User function code 19	F00.00~F25.xx	0.01	25.00	○
F25.19	User function code 20	F00.00~F25.xx	0.01	25.00	○
F25.20	User function code 21	F00.00~F25.xx	0.01	25.00	○
F25.21	User function code 22	F00.00~F25.xx	0.01	25.00	○
F25.22	User function code 23	F00.00~F25.xx	0.01	25.00	○
F25.23	User function code 24	F00.00~F25.xx	0.01	25.00	○
F25.24	User function code 25	F00.00~F25.xx	0.01	25.00	○
F25.25	User function code 26	F00.00~F25.xx	0.01	25.00	○
F25.26	User function code 27	F00.00~F25.xx	0.01	25.00	○
F25.27	User function code 28	F00.00~F25.xx	0.01	25.00	○
F25.28	User function code 29	F00.00~F25.xx	0.01	25.00	○
F25.29	User function code 30	F00.00~F25.xx	0.01	25.00	○

## F26-Fault Record Function Parameter Group

Function code	Name	Set range	Min. unit	Factory default	Modification
F26.00	The last fault record	0:No fault 1:Overcurrent at acceleration 2:Overcurrent at deceleration 3:Overcurrent at constant speed 4:Overvoltage at acceleration 5:Overvoltage at deceleration 6:Overvoltage at constant speed 7:Overvoltage at motor halt 8:Undervoltage at run 9:Drive overload protection 10:Motor overload protection 11:Motor under load protection 12:Input phase loss 13:Output phase loss 14:Inverter module protection 15:Short circuit to earth at run 16:Short circuit to earth when power on	1	0	*

## 5 Function parameter schedule graph

		17:Drive overheat 18:External device fault 19:Current detect circuit fault 20:External interference 21:Internal interference-main clock etc 22:PID provide lost 23:PID feedback lost 24:PID error value abnormal 25:Terminal protection activate 26:Communication fault 27~29:Reserve 30:E <sup>2</sup> ROM read-write error 31:Temperature detection disconnection 32:Auto-tunning fault 33:Contactor abnormal 34:Factory fault 1 35:Factory fault 2 36:Reserved 37:Coder broke line 38:Over speed protection 39:Speed deviate too large protection 40:Z purse missing fault 41:Analog channel broke line protection 42~50: Reserved			
F26.01	The last two fault records	Same as above	1	0	*
F26.02	The last three fault records	Same as above	1	0	*
F26.03	The last four fault records	Same as above	1	0	*
F26.04	Setup frequency at the last one fault	0.00Hz~Upper limit frequency	0.01Hz	0	*
F26.05	Output frequency at the last one fault	0.00Hz~Upper limit frequency	0.01Hz	0	*
F26.06	Output current at the last one fault	0.0~6553.5A	0.1A	0.0A	*
F26.07	DC bus voltage at the last one fault	0.0~6553.5V	0.1V	0.0V	*
F26.08	Module temperature at the last one fault	0~125℃	1℃	0℃	*
F26.09	Input terminal status at the last one fault			0	*
F26.10	Accumulated run time at the last one fault	0~65535h	1h	0	*
F26.11	Setup frequency at the last two fault	0.00Hz~Upper limit frequency	0.01Hz	0.00Hz	*
F26.12	Output frequency at the last two fault	0.00Hz~Upper limit frequency	0.01Hz	0.00Hz	*
F26.13	Output current at the last two fault	0.0~6553.5A	0.1A	0.0A	*
F26.14	DC bus voltage at the last two fault	0.0~6553.5V	0.1V	0.0V	*
F26.15	Module temperature at the last two fault	0~125℃	1℃	0℃	*

## 5 Function parameter schedule graph

F26.16	Input terminal status at the last two fault			0	*
F26.17	Accumulated run time at the last two fault	0~65535min	1min	0min	*

### F27-Password and Manufacturer Function Parameter Group

Function code	Name	Set range	Min. unit	Factory default	Modification
F27.00	User password	00000~65535	1	00000	○
F27.01	Manufacturer password	00000~65535	1	00000	○

### C-Monitor Function Parameter Group

Function code	Name	Set range	Min. unit	Factory default	Modification
C-00	Display the parameter of F00.01, F00.07 definition				
C-01	Display the parameter of F00.02, F00.08 definition				
C-02	Display the parameter of F00.03, F00.09 definition				
C-03	Display the parameter of F00.04, F00.10 definition				
C-04	Display the parameter of F00.05, F00.11 definition				
C-05	Display the parameter of F00.06, F00.12 definition				

(1) Corresponding relationship of input terminal status as below:

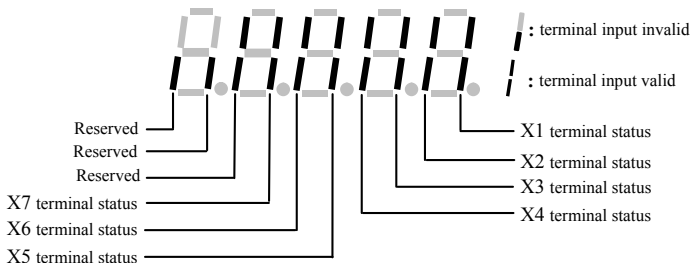

## 5 Function parameter schedule graph

(2) Corresponding relationship of standard output terminal status as below:

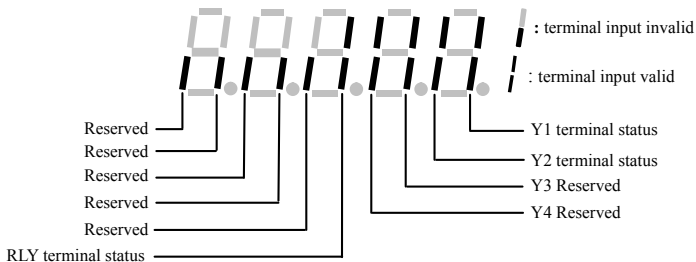

(3) Corresponding relationship of communication virtual input terminal status as below:

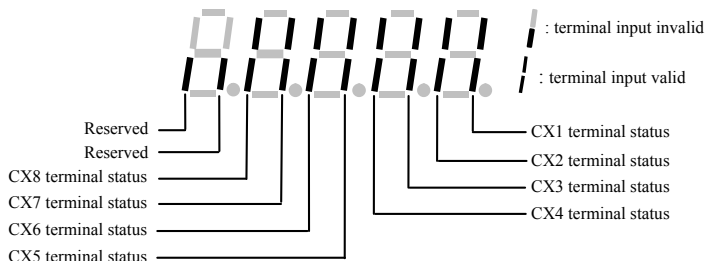

(4) Drive status:

- BIT0:1=DC bus voltage setup
- BIT1:1=common run command valid
- BIT2:1=jog run command valid
- BIT3:1=drive run period
- BIT4:1=current run direction to reverse
- BIT5:1=run command direction to reverse
- BIT6:1=deceleration brake period
- BIT7:1=motor acceleration period
- BIT8:1=motor deceleration period
- BIT9:1=drive alarm
- BIT10:1=drive fault
- BIT11:1=current limited period

BIT12:1=fault self-recovery period

BIT13:1=self-adjusting period

BIT14:1=free halt status

BIT15:1=speed tracking start

## 6 Troubleshooting

### 6.1 Failure and countermeasure

Possible failure types in EN630/EN650A are shown in Table 6-1, the fault types including fault and alarm. Such as if inverter fault display E-XX , while the corresponding alarm is displayed in A-XX . Once the inverter failure , fault types are stored in the F26 fault recording parameter group, and if alarm, alarm status has been revealed, until the alarm source release, alarm status are not logged to the F26 parameter group. Some failure code is reserved for intelligent automatic diagnosis function which will be executed continuously in future. When failure takes place in the inverter, the user should check according to note of this table first and record failure phenomena detailedly. Please contact our after-sale service and technical support Department or agent in your local place when technical service is needed.

**Table 6-1 Failure type and the countermeasure**

Failure code	Failure type	Possible reason	Countermeasure
E-01	Overcurrent during accelerating process	Accelerating time is too short	Prolong accelerating time
		Improper V/F curve	Adjust V/F curve setting, adjust manual torque boost or change to automatic torque boost
		Restart rotating motor	Set speed checking restart function
		Low power source voltage	Check input power supply
		Too small power of the inverter	Choose inverter with higher power
		Output phase lose under vector control	Check whether the motor wiring is in good condition
E-02	Overcurrent during decelerating process	Decelerating time is too short	Prolong decelerating time
		Have potential energy load or big inertia load	Increase braking power of external energy consumption braking subassembly
		Power of inverter is a bit small	Choose inverter with higher power
E-03	Overcurrent during constant speed process	Load change suddenly or have unwanted phenomena	Check or reduce break of the load
		Acc/Dec. time is set too short	Prolong accelerating decelerating time properly
		Low power source voltage	Check input power supply



		Power of inverter is a bit small	Choose inverter with higher power
E-04	Overvoltage during accelerating process	Unwanted input voltage	Check input power supply
		Acc time is set too short	Prolong accelerating time properly
		Restart rotating motor	Set speed checking restart function
E-05	Overvoltage during decelerating process	Decelerating time is too short	Prolong decelerating time
		Have potential energy load or big inertia load	Increase braking power of external energy consumption braking subassembly
E-06	Overvoltage during constant speed process	Unwanted input voltage	Check input power supply
		Acc./Dec. time is set too short	Prolong accelerating decelerating time properly
		Input voltage change abnormally	Assemble input reactor
		Load inertia is a bit big	Use energy consumption subassembly
E-07	Overvoltage when stopped	Unwanted input voltage	Check input power supply or look for service
E-08	Low-voltage when running	Input voltage is too low	Check the input voltage
E-09	Inverter overload protection	Acc time is set to too short	Prolong accelerating time
		DC braking is too big	Reduce DC braking Current, prolong braking time
		Improper V/F curve	Adjust V/F curve and torque boost
		Restart rotating motor	Set speed checking restart function
		Power source voltage is too low	Check power source voltage
		Load is too big	Choose inverter with higher power
E-10 (A-10)	Motor overload protection	Improper V/F curve	Adjust V/F curve and torque boost
		Power source voltage is too low	check power source voltage
		General motor run at low speed with big load	Can choose frequency conversion motor for long time low speed run

		Motor overload protection factor set incorrectly	to set motor overload protection factor correctly
		Motor blocked up or load change too suddenly and quickly	Check the load
E-11 (A-11)	Motor under-load protection	The operating current of inverter less than under-load threshold	Confirm whether the parameters F19.08, F19.09 setting are reasonable
		load divorced from motor	Checking whether the load divorced from motor
E-12	The input phase lose	The three-phase input power supply is abnormal	Check the three-phase input power line is off or poor contact
		Power supply board anomaly	Look for service from manufacturer or agent
		The control board anomaly	Look for service from manufacturer or agent
E-13	The output phase lose	The cable from inverter to motor anomaly	Checking the cable
		When the motor runs inverter three-phase output unbalanced	Check whether the motor three-phase winding is balance
		Power supply board anomaly	Look for service from manufacturer or agent
		The control board anomaly	Look for service from manufacturer or agent
E-14	Inverting module protection	Transient overcurrent of the inverter	Refer to countermeasure for overcurrent
		phase to phase short circuit or earthing short circuit of output 3 phase	wiring again
		Air-path blocked or fan damaged	To clear air-path or replace the fan
		Ambient temperature is too high	Lower ambient temperature
		Connecting wire or insert on control board loose	Check and connect the wire again
		Unwonted current wave caused by missing output phase etc.	Check wiring
		Assistant power supply damaged and drive voltage lacking	Look for service from manufacturer or agent

		Unwanted control board	Look for service from manufacturer or agent
E-15	Short circuit to ground when operation	Motor short circuit to ground	The replacement of cable or motor
		Hall component is damaged or the hall wiring is poor or the current detection circuit is abnormal	Look for service from manufacturer or agent
E-16	Short circuit to ground when power on	Motor short circuit to ground	Change the cable or motor
		The power supplier of the inverter and the motor wiring are reversed	Change the cable or motor wiring
		Hall component is damaged or the hall wiring is poor	Look for service from manufacturer or agent
E-17 (A-17)	Inverter overheat	Duct blockage	Cleaning or to improve the ventilation duct
		The ambient temperature is too high	To improve the ventilation conditions, decreasing the carrier frequency
		Fan damage	Change new one
		External fault emergency stop terminal closed	External fault disconnect after external fault terminal
E-18 (A-18)	External device failure	Sudden stop terminal for external failure closed	Open external failure terminal after external failure is settled
E-19	Current detecting circuit failure	Connecting wire or insert on control board loose	Check and connect the wire again
		Assistant power supply damaged	Look for service from manufacturer or agent
		Hall component damaged	Look for service from manufacturer or agent
		Unwanted amplifying circuit	Look for service from manufacturer or agent
E-20	External interference failure	External disturbance serious	Press "STOP/RESET" button to reset or add external power supply filter from power input side
E-21	External interference failure	External disturbance serious	Power off and restart, if the failure persists, seek the manufacturer or dealer service
E-22 (A-22)	PID Given loss	PID given loss threshold setting is not reasonable	To reset the relevant parameters

		External given disconnection	Check external given wiring
		The control board anomaly	Look for service from manufacturer or agent
E-23 (A-23)	PID feedback loss	PID feedback loss threshold setting is not reasonable	To reset the relevant parameters
		Feedback signal disconnection	Check external feedback signal wiring
		The control board anomaly	Look for service from manufacturer or agent
E-24 (A-24)	PID error amount abnormal	PID error abnormal detection threshold setting is not reasonable	To reset the relevant parameters
		The control board anomaly	Look for service from manufacturer or agent
E-25	Start terminal protection	Terminal command effective when power on .	Check the external input terminal state
E-26 (A-26)	Communication failure	Baud rate set improperly	Set Baud rate properly
		Serial port communication error	Press "STOP/RESET" key to reset, look for service
		Failure warning parameter set improperly	Modify F05.04, F05.05
		Upper device doesn't work	Check if upper device work and wiring is correct
E-27 ~ E-29	Reserved		
E-30 (A-30)	E <sup>2</sup> PROM read and write wrongly	Mistake take place when read or write control parameter	Reset by pressing "STOP/RESET" Look for service from manufacturer or agent
E-31	Temperature detecting disconnection	Temperature sensor fault	Look for service from manufacturer or agent
		The temperature detection circuit anomaly	Look for service from manufacturer or agent
E-32	Self tuning failure	Parameter setting not according to the motor nameplate	set parameter correctly according to the motor nameplate
		current anomaly when tuning	Select inverter match the motor
		Motor wiring error	Check the motor three-phase wiring

E-33 (A-33)	Contactor anomaly	Power board anomaly	Look for service from manufacturer or agent
		Contactor anomaly	Replace contactor
E-34	The fault 1	Debugging use in factory	
E-35	The fault 2	Debugging use in factory	
E-36 (A-36)	Reserved		
E-37	Encoder disconnection	Damaged encoder or poor wiring	Check the wiring or the encoder
E-38	Over speed protection	Short accelerating time	Prolong the accelerating time
		Low inverter power	Select higher power inverter
		Over speed detect parameter F19.39 and F19.40 is set improperly	Set the parameter properly according to the situation
E-39	Large speed deviation protection	Acceleration/deceleration time is too short	Prolong the acceleration time
		Low inverter power	Select higher power inverter
		Over velocity misalignment, Parameter F19.41 and F19.42 is set improperly	Set the parameter properly according to the situation
E-40	Fault of Z pulse loses	Z signal wire of motor encoder is unconnected or loose	Check the Z signal wire of motor encoder
E-41	Analog channel disconnection	A11 or A12 detection of the physical quantity is not within a reasonable range, or A11 or A12 circuit bad contact	Reasonably control the physical quantities measured by A11 or A12, check the wiring of A11 or A12.
E-42 ~ E-50	Reserved		
A-51	The main and Auxiliary given frequency channel exclusiveness alarm	Parameter setting error	F01.00 and F01.03 cannot be set to the same channel (9: terminal encoder given except)
A-52	Terminal function exclusiveness alarm	Terminal function parameters setting repeatedly	Check the terminal function settings

A-53	Run limit alarm	Reach limited running time	Please contact your supplier
LOCH1.	Keypad lock	Keypad buttons lock	Check chapter 4.2.6



Note

- (1) Alarm fault of E-16, the inverter must power off for reset.  
 (2) For the faults of over-current, short-circuit to ground while running, inverter can reset after 2s delay.

## 6.2 Failure record lookup

This series inverter can record latest 4 failure code and inverter run parameter of the last 2 times failure, to search these information can redound to finding out reason of the failure.

Failure information is all stored in F26 group parameter, please enter into F26 group parameter to see about information by referring to keypad operation method.

Code	Content	Code	Content
F26.00	Previous one failure record	F26.09	Input terminal state at previous failure
F26.01	Previous two failure record	F26.10	Total running time at previous failure
F26.02	Previous three failure record	F26.11	Set freq. at previous 2 failure
F26.03	Previous four failure record	F26.12	Output freq. at previous 2 failure
F26.04	Set freq. at previous failure	F26.13	Output current. at previous 2 failure
F26.05	Output freq. at previous failure	F26.14	DC bus volt. at previous 2 failure
F26.06	Output current. at previous failure	F26.15	Module temp. at previous 2 failure
F26.07	DC bus volt. at previous failure	F26.16	Input terminal state of previous 2 failure
F26.08	Module temp. at previous failure	F26.17	Total running time of previous 2 failure

### 6.3 Failure reset



- (1) Before reset you must find out reason of failure downright and eliminate it, otherwise may cause permanent damage to the inverter.
- (2) If can't reset or failure takes place again after resetting, should look for reason and continuous resetting will damage the inverter.
- (3) Reset should take place 5 minutes later after overload, overheat protection action.
- (4) For the failure of E-14, the reset is invalid, the motor wiring should be checked after power off, and restart the inverter.
- (5) When there is a fault of E-16 after power on, do not directly run the inverter after reset, and need to check whether the input, out wiring are reversed.

To resume normal running when failure takes place in the inverter, you can choose following any kind of operation:

- (1) After you set any terminal of X1~X8 to be inputted by external RESET, it will be disconnected after connected to COM.
- (2) When failure code is displayed, press  key after restoration is confirmed.
- (3) Communication reset. Please refer to annex description.
- (4) Cut off power supply.

### 6.4 Alarm reset

When an alarm occurs, must eliminate alarm source which cause alarm, otherwise the alarm can not be eliminated, also cannot be reset by reset button.

## 7 Maintenance

### 7.1 Routine maintenance

When you use this series you must assemble and operate it according to demand listed in this “service manual” strictly. During run state, temperature, humidity, vibration and aging parts will affect it, which may cause failure of the inverter. To avoid this, it is recommended to perform routine inspections and maintenance.

**Table 7-1 Daily inspection and maintenance items**

Period		Inspection item
Daily	Periodic	
√		Daily cleaning: (1) Inverter should be maintained in a clean state (2) Clean up the dust on the surface of inverter, prevent the dust into the inverter internal (especially metal dust). (3) Clean up the oil stain of cooling fan
	√	Check the air duct, and regularly clean.
	√	Check whether the screws is loose
	√	Check whether the inverter is corrode
√		Whether inverter installation environment changes
√		Whether the inverter cooling fan is working properly
√		Whether the inverter is overheating
√		When motor running whether voice abnormally changes.
√		Whether occur abnormal vibration when motor running
	√	Check whether wiring terminals have arc trace
	√	The main circuit insulation test

Recommend to inspect with following instrument:

Input voltage: electric voltmeter; output voltage: rectifying voltmeter; input output current: pincers ammeter

### 7.2 Inspection and replacement of damageable parts

Some component parts in the inverter will be abraded or bear descending performance for long-term usage, to assure that the inverter can run stably and reliably, it is recommended to perform defending maintenance and replace corresponding parts if necessary.

#### (1) Cooling fan

Abnormal noise, even oscillation may take place if the fan have wearing



bearing, aging blade, here replacement of the fan should be considered.

(2) Filter electrolyte capacitance

When frequent-changing load causes increasing pulsating current and aging electrolyte under high ambient temperature, the electrolyte capacitance may be damaged and here should replace it.

### 7.3 Repair guarantee

(1) We provide the free maintenance within warranty time if any failure or damage under normal usage, the warranty time can be seen in the warranty card, we will charge some when exceed warranty time.

(2) We will take some upkeep if one of following situations takes place within period of repair guarantee.

a. If did not use the inverter according to<Service manual>strictly or did not use it under ambient demanded in<Service manual>, which cause failure.

b. Failure caused by applying the inverter to non-normal function;

c. Failure caused by self-repair, refit which is not already allowed;

d. Damage caused by bad keeping, falling down from high place or other extrinsic factor after purchasing the inverter;

e. Failure caused by natural disaster or its reason such as unwonted voltage, thunderbolt, water fog, fire, salt corroding, gas corroding, earthquake and storm etc.;

f. Make bold to tear up product logo (Such as: nameplate etc.); Body serial number don't accord with that in repair guarantee card.

(3) We calculate service fee based on actual cost, which is subject to contract if any.

(4) You can contact the agent and also our company directly if you have questions. After repair guarantee period, we shall also provide lifetime charged repair service for our products.



**Note**

Our company will also provide lifetime repair service with fee for inverter which is not within period of repair guarantee.

### 7.4 Storage

The user must pay attention to following points for temporary storage and long-term storage after purchasing the inverter:

(1) Avoid storing the inverter in high temperature, moist place and place of dust, metal powder and assure good ventilation.

(2) Longtime storage will cause low quality of electrolyte capacitance, so must assure that it's electrified for one time within 1 year and electrification time is not shorter than 1 hour and input voltage must be increased to rated value gradually by voltage regulator of 250w, meanwhile the inverter should be cut off from the motor.

## Appendix A EN650A Mini multi-function PMSM Inverter

### A.1 Symbol description







- × ---- parameter can't be changed in process of running
- ---- parameter can be changed in process of running
- \* ---- read-only parameter, unchangeable

### A.2 Function parameter schedule graph

F00-System Parameter Group					
Function code	Name	Set range	Min. unit	Factory Default	Modification
F00.00	Parameter group display control	0: Basic list mode (Only display F00–F03 basic control parameter group and F26 fault record parameter group.) 1: Middle list mode. Display all parameter except for extension: virtual and reserve parameter group. 2: Senior list mode. All parameter display. 3: User list mode. Display parameter defined by user: and monitor parameter: F00.00 display all the time. Note: Under mode 1, some related parameters would be hidden according to motor and control mode.	1	0	○
F00.01	C-00 display parameter selection when operation	0:Main setup frequency (0.01Hz) 1:Auxiliary setup frequency (0.01Hz) 2:Setup frequency (0.01Hz) 3:Output frequency (0.01Hz) 4:Output current (0.1A) 5:Output voltage (1V) 6:DC bus voltage (0.1V) 7:Motor speed (1 circle/min) 8:Motor line velocity (1 circle/min) 9:Inverter temperature (1°C) 10:Run time already this time (0.1min) 11:Current accumulate run time (1h) 12:Current accumulate power-on time (1h) 13:Inverter status 14:Input terminal status 15:Output terminal status (Standard) 16:Extension output terminal status 17:Extension input terminal status 18:Communication virtual input terminal status 19:Internal virtual input node status 20:Analog input AI1(After checkout) (0.01V/0.01mA)	1	3	○

		21:Analog input AI2(After checkout) (0.01V/0.01mA) 22:Extension analog input EAI1(after checkout) (0.01V/0.01mA) 23:Extension analog input EAI2(after checkout) (0.01V/0.01mA) 24:Analog AO1 output(after checkout) (0.01V/0.01mA) 25:Analog AO2 output(after checkout) (0.01V/0.01mA) 26:Extension analog EAO1 output (0.01V /0.01mA) 27: Extension analog EAO2 output (0.01V /0.01mA) 28:External pulse input frequency(before checkout)(1Hz) 29:Reserved 30:Process PID provide(0.01V) 31:Process PID feedback(0.01V) 32:Process PID deviation (0.01V) 33:Process PID output (0.01Hz) 34: Simple PLC current segment No. 35: External multi-speed current segment No. 36:Reserved 37:Reserved 38:Reserved 39:Current length (1M) 40:Accumulate length (1M) 41:Current internal count value 42:Current internal time value(0.1s) 43:run command setup channel(0:keyboard 1:terminal 2:communication) 44:main frequency provide channel 45:auxiliary frequency provide channel 46:rated current(0.1A) 47:rated voltage(1V) 48:rated power(0.1KW) 49:Inverter provision torque(percentage of rated torque with direction) 50:Inverter output torque (1 N.M) 51~65:Reserved			
F00.02	C-01 display parameter selection when operation	Same as above	1	2	○
F00.03	C-02 display parameter selection when operation	Same as above	1	4	○
F00.04	C-03 display parameter selection when operation	Same as above	1	5	○
F00.05	C-04 display parameter	Same as above	1	6	○

## Appendix A EN650A Mini multi-function PMSM Inverter

	selection when operation				
F00.06	C-05 display parameter selection when operation	Same as above	1	9	○
F00.07	C-00 display parameter selection when stop	Same as above	1	2	○
F00.08	C-01 display parameter selection when stop	Same as above	1	6	○
F00.09	C-02 display parameter selection when stop	Same as above	1	48	○
F00.10	C-03 display parameter selection when stop	Same as above	1	14	○
F00.11	C-04 display parameter selection when stop	Same as above	1	20	○
F00.12	C-05 display parameter selection when stop	Same as above	1	9	○
F00.13	Power-on default monitor parameter selection	0~5	1	0	○
F00.14	Parameter operation control	<p>Units digit: Parameter modification operations</p> <p>0: All parameters are allowed to be modified</p> <p>1: Except current parameter, all other parameters are not allowed to modify the</p> <p>2: Except F01.01, F01.04 and current parameter, all other parameters are not allowed to be modified</p> <p>Tens digit: Reset to factory defaults</p> <p>0: No action.</p> <p>1: All parameters return to default. (not include fault record parameter group (F26 group) parameter).</p> <p>2: Except for motor parameter: all parameters return to default. (not include F15 and F26 group parameter).</p> <p>3: Extension parameter return to default. (only F21~F24 group parameter return to default).</p> <p>4: Virtual parameter return to default. (only F20 group parameter return to default).</p> <p>5: Fault record return to default. (only fault record parameter group (F26 group) parameter return to default)</p> <p>Hundreds digit: Key operation</p> <p>0: All locked</p> <p>1: Except  button: the others locked</p> <p>2: Except    button: the others locked</p> <p>3: Except   button: the others locked</p>	1	000	×

		4:Except (>>), (STOP) button: the others locked			
F00.15	Button function selection	<p>Units digit: panel (STOP) button selection  0:Reversal command action button  1:Jog action button  Tens digit: (STOP) multi-function button function selection  0: Invalid.  1: Jog run. multi-function button as jog run button, run direction decided by unit bit of F01.16's .  2: For/rev switching. press this button to change the run direction when run: then press the same button change to another direction.  3: Free stop. setup free stop function and stop mode F02.11 the same function with 1 Jog run.  4: Switching to run command provide mode as the setup order of F00.16.  5:Forward/Reverse Torque Switching  6~9:Reserved  Hundreds digit: terminal run command control  0:Keyboard (STOP) button invalid  1:Keyboard (STOP) button valid  Thousands digit: communication run command control  0:Keyboard (STOP) button invalid  1:Keyboard (STOP) button valid</p>	1	0001	○
F00.16	Multi-function key run command channel switching order selection	<p>0: Keyboard control→ terminal control→ communication control  1: Keyboard control←→terminal control  2: Keyboard control←→communication control  3: Terminal control←→communication Control</p>	1	0	○
F00.17	Motor speed display coefficient	0.1~999.9%	0.1%	100.0%	○
F00.18	Line speed display coefficient	0.1~999.9%	0.1%	1.0%	○
F00.19	PG card selection	<p>0:Invalid  1:Reserved  2:Reserved  3:incremental encoder (F08.24 can not be 91) (Terminal X6,X7 relating to A,B terminal X5relating to Z)  4~10:Reserved</p>	1	0	×

## Appendix A EN650A Mini multi-function PMSM Inverter

F00.20	Analog input terminal configuration	Units digit: AI1 configuration 0:0~10V input 1:4~20mA input Tens digit: AI2 configuration 0:-10~10V input 1:4~20mA input Hundreds digit: Reserved Thousands digit: Reserved	1	0000	×
F00.21	Analog output terminal configuration	Units digit: AO1 configuration 0:0~10V output 1:4~20mA output Tens digit: AO2 configuration 0:0~10V output 1:4~20mA output Hundreds digit: Reserved Thousands digit: Reserved	1	0000	×
F00.22	Youtput terminal configuration	Units digit~ hundreds digit: reserved Thousands digit: Y2 output configuration 0:Open-collector output 1:DO output	1	0000	×
F00.23	Reserved				
F00.24	Motor control mode	0:V/F Control mode (Asynchronous motor available) 1:Without PG vector control(PMSM and asynchronous motor available) 2:With PG vector control (For PMSM)	1	1	×
F00.25	Motor type selection	0:Asynchronous motor (Speed control mode) 1:MPSM (Speed control and torque control mode)	1	1	×
F00.26	Reserved				
F00.27	Reserved				

### F01-Basic Run Function Parameter Group

Function code	Name	Set range	Min. unit	Factory Default	Modification
F01.00	Main frequency input channel selection	0: Operation keyboard digital setup 1: AI1 analog setup 2: AI2 analog setup 3:Terminal UP/DOWN adjusting setup 4: Communication provision. 5:Reserved 6:Reserved 7:High speed pulse setup(Select matched function for X7 terminal) 8~14:Reserved	1	0	○
F01.01	Main frequency digital setup	0.00Hz~upper limit frequency	0.01 Hz	50.00Hz	○
F01.02	Main frequency digital control	Only when parameter F01.00=0:3:4 valid. Units digit: power down reserve setup	1	00	○

## Appendix A EN650A Mini multi-function PMSM Inverter

		0: Main frequency power down reserve. 1: Main frequency power down no reserve. Tens digit: halt reserve setup 0:Halt main frequency hold 1:Halt main frequency recovery F01.01			
F01.03	Auxiliary frequency input channel selection	0: Operation keyboard digital setup 1: A11 analog setup 2: A12 analog setup 3:Terminal UP/DOWN adjusting setup 4: Communication provision. 5:Reserved 6:Reserved 7:High speed pulse setup(Select matched function for X7 terminal) 8~20:Reserved	1	1	○
F01.04	Auxiliary frequency digital setup	0.00Hz~upper limit frequency	0.01 Hz	0.00Hz	○
F01.05	Auxiliary frequency digital control	Units digit: power down reserve setup 0: Auxiliary frequency power down reserve. 1: Auxiliary frequency power down no reserve. Tens digit: halt reserve setup 0: Halt auxiliary frequency hold. 1: Halt auxiliary frequency recovery parameter F01.04	1	11	○
F01.06	Main and auxiliary provide calculating setup	0: Main frequency (Complex frequency of current is main frequency). 1: Auxiliary frequency (Complex frequency of current is auxiliary frequency.) 2: Plus (Polarity oppose of complex and main frequency, complex frequency is zero). 3: Minus (polarity oppose of complex and auxiliary frequency, complex frequency is zero). 4: Multiplication (polarity opposed of main and auxiliary frequency: complex frequency is zero). 5: Max (the max frequency of main and auxiliary absolute value). 6: Min (the min frequency of main and auxiliary absolute value). 7:Selection no-zero value(auxiliary is not negative, main frequency prior; auxiliary is negative, complex frequency is zero).	1	0	○
F01.07	Auxiliary frequency provide coefficient	0.00~10.00	0.01	1.00	○
F01.08	Coefficient after complex of main and auxiliary frequency	0.00~10.00	0.01	1.00	○
F01.09	Auxiliary frequency range selection	0: Relative upper limit frequency. 1: Relative main frequency.	1	0	○
F01.10	Auxiliary frequency	0.00~1.00	0.01	1.00	○

## Appendix A EN650A Mini multi-function PMSM Inverter

	source scope				
F01.11	upper limit frequency	low limit frequency~600.00Hz	0.01Hz	50.00Hz	×
F01.12	Low limit frequency	0.00Hz~upper limit frequency	0.01Hz	0.00Hz	×
F01.13	Low limit frequency run mode	0: As low limit frequency run. 1: As setting frequency run. 2: As zero frequency run. 3: Sleep: PWM clocked at sleep mode.	1	0	×
F01.14	Sleep run hysteresis frequency	0.01Hz~upper limit frequency (This function can be used to finish the sleep mode function, realizing energy-saving operation process, and the hysteresis width can avoid inverter starting frequently in threshold)	0.01 Hz	0.01Hz	○
F01.15	Run command channel selection	0: Operation keyboard run control. 1: Terminal run command control 2: Communication run command control.	1	0	○
F01.16	Run direction setup	Units digit: Keyboard command for/rev setup(only valid to keyboard inching command) 0: Forward 1: Reverse Tens digit: for/rev forbid(suitable for all command channel, not include inching function) 0: Forward /reverse available. 1: Reverse not available (Imposing on reverse, stop as the halt mode). 2: Forward not available (Imposing on forward, stop as the halt mode)	1	00	○
F01.17	Acceleration time 1	1~60000(Acceleration time is interval accelerate from zero frequency to upper limit frequency)	1	Base on motor type	○
F01.18	Deceleration time 1	1~60000(Deceleration time is the interval decelerate from upper limit frequency to zero frequency.)	1	Base on motor type	○
F01.19	Acc/Dec time unit	0:0.01s 1:0.1s 2:1s	1	1	×
F01.20	Acc/Dec mode selection	0: Line Acc/Dec mode. 1: S curve acc/Dec mode.	1	0	×
F01.21	S curve acceleration initiation segment time	10.0%~50.0% (Acceleration/deceleration time) S curve deceleration start time+ S curve deceleration raise time ≤90% )	0.1%	20.0%	○
F01.22	S curve acceleration up segment time	10.0%~70.0% (Acceleration/deceleration time) S curve acceleration start time+ S curve acceleration raise time ≤90% )	0.1%	60.0%	○
F01.23	S curve deceleration initiation segment time	10.0%~50.0% (Acceleration/deceleration time) S curve acceleration start time+ S curve acceleration raise time ≤90% )	0.1%	20.0%	○



## Appendix A EN650A Mini multi-function PMSM Inverter

F01.24	S curve deceleration up segment time	10.0%~70.0% (Acceleration/deceleration time) S curve acceleration start time+ S curve acceleration raise time ≤90% )	0.1%	60.0%	○
F01.25	Keyboard jog run frequency	0.00Hz~upper limit frequency	0.01 Hz	5.00Hz	○
F01.26	Terminal jog run frequency	0.00Hz~upper limit frequency	0.01 Hz	5.00Hz	○
F01.27	Jog interval time	0.0~100.0s	0.1s	0.0s	○
F01.28	Jog acceleration time	0.1~6000.0s	0.1s	20.0s	○
F01.29	Jog deceleration time	0.1~6000.0s	0.1s	20.0s	○

<b>F02-Start, stop, Forward/Reverse, brake function parameter group</b>					
Function Code	Name	Set range	Min. Unit	Factory Default	Modification
F02.00	Start mode	0:Start from starting frequency 1:Brake first and then start from starting frequency(Invalid for PMSM) 2:Start by revolving speed tracking(Invalid for PMSM)	1	0	×
F02.01	Starting delay time	0.0~60.0s	0.1s	0.0s	×
F02.02	Starting frequency	0.0~10.00Hz	0.01 Hz	0.00Hz	×
F02.03	Starting frequency duration time	0.0~60.0s	0.1s	0.0s	×
F02.04	DC braking current when starting	0.0~100.0%	0.1%	30.0%	×
F02.05	DC braking time when starting	0.0~30.0s	0.1s	0.0s	×
F02.06	Speed track starting frequency selection	0:Current setting frequency 1:Running frequency before power down 2:Speed track auxiliary starting frequency	1	2	×
F02.07	Speed track auxiliary starting frequency	0.00Hz~Upper limit Fre.	0.01 Hz	10.00Hz	×
F02.08	Speed track starting waiting time	0.00~10.00s	0.01s	0.10s	×
F02.09	Speed track current control coefficient	1~20	1	2	×
F02.10	Speed track searching speed time	0.1~30.0s	0.1s	10.0s	×
F02.11	Stop mode	0: Deceleration stop 1: Free stop 2:Deceleration + DC braking stop (Invalid for PMSM)	1	0	×
F02.12	Deceleration stop holding frequency	0.00~upper limit frequency(Only valid for stop mode 0)	0.01 Hz	0.00Hz	×
F02.13	Deceleration stop holding time	0.00~10.00s	0.01s	0.00s	×
F02.14	Stop DC braking	0.00~15.00Hz	0.01	0.00Hz	×

## Appendix A EN650A Mini multi-function PMSM Inverter

	starting frequency		Hz		
F02.15	stop DC braking waiting time	0.00~30.00s	0.01s	0.00s	×
F02.16	Stop DC braking current	0.0~100.0%	0.1%	0.0%	×
F02.17	Stop DC braking time	0.0~30.0s	0.1s	0.0s	×
F02.18	Stop auxiliary braking current	0.0~100.0%	0.1%	0.0%	×
F02.19	Stop auxiliary braking time	0.0~100.0s	0.1s	0.0s	×
F02.20	Forward/reverse dead zone time	0.0~3600.0s	0.1s	0.1s	×
F02.21	Forward/Reverse switching mode	0: Over zero switchover 1: Over starting frequency switchover	1	0	×
F02.22	Energy consumption braking selection	0: No energy consumption braking 1: Energy consumption braking	1	0	○
F02.23	Energy consumption braking voltage	115.0~145.0%(rated DC BUS voltage)	0.1%	125.0%	○
F02.24	Energy consumption braking use rate	0.0~100.0%	0.1%	50.0%	○
F02.25	Reserved				
F02.26	Reserved				

F03-V/F control parameter group					
Function Code	Name	Set range	Min. Unit	Factory Default	Modification
F03.00	V/F curve setting	0:Constant torque curve 1:Degression torque curve 1 (2.0 power) 2:Degression torque curve 1 (1.7 power) 3:Degression torque curve 3 (1.2 power) 4: User self-defined setting V/F curve (Confirmed by F03.04~F03.11)	1	0	×
F03.01	Torque boost mode	0: Manual boost. 1:Auto torque boost	1	0	○
F03.02	Torque boost	0.0~12.0%	0.1%	Base on motor type	○
F03.03	Torque boost cut-off frequency	0.0~100.0% (Motor rated frequency)	0.1%	20.0%	○
F03.04	V/F frequency value 0	0.00~V/F frequency value 1	0.01 Hz	10.00Hz	×
F03.05	V/F voltage value 0	0.00~V/F voltage value 1	0.01%	20.00%	×
F03.06	V/F frequency value 1	V/F frequency value 0~V/F frequency value 2	0.01Hz	20.00Hz	×
F03.07	V/F voltage value 1	V/F voltage value 0~V/F voltage value 2	0.01%	40.00%	×
F03.08	V/F frequency value 2	V/F frequency value 1~V/F frequency value 3	0.01Hz	25.00Hz	×
F03.09	V/F voltage value 2	V/F voltage value 1~V/F voltage value 3	0.01%	50.00%	×

## Appendix A EN650A Mini multi-function PMSM Inverter

F03.10	V/F frequency value 3	V/F frequency value 2~upper limit frequency	0.01 Hz	40.00Hz	×
F03.11	V/F voltage value 3	V/F voltage value 2~100.00% (Motor rated voltage)	0.01%	80.00%	×
F03.12	V/F oscillation suppression factor	0~255	1	10	○

### F04-Auxiliary running parameter group

Function Code	Name	Set range	Min. Unit	Factory Default	Modification
F04.00	Jump freq.1	0.00Hz~upper limit frequency	0.01Hz	0.00Hz	×
F04.01	Jump freq.1 range	0.00Hz~upper limit frequency	0.01Hz	0.00Hz	×
F04.02	Jump freq.2	0.00Hz~upper limit frequency	0.01Hz	0.00Hz	×
F04.03	Jump freq.2 range	0.00Hz~upper limit frequency	0.01Hz	0.00Hz	×
F04.04	Jump freq.3	0.00Hz~upper limit frequency	0.01Hz	0.00Hz	×
F04.05	Jump freq.3 range	0.00Hz~upper limit frequency	0.01Hz	0.00Hz	×
F04.06	Slip freq. gain	0.0~300.0%	0.1%	0.0%	×
F04.07	Slip compensation limit	0.0~250.0%	0.1%	100.0%	×
F04.08	Slip compensation time constant	0.1~25.0s	0.1s	2.0s	×
F04.09	Carrier freq.	0.5~16.0K	0.1K	Based on motor type	○
F04.10	PWM optimized adjustment	Units digit: Carrier freq. is adjusted automatically according to temperature 0: Banned. 1: Allowed. Tens digit: low speed carrier freq. limit mode 0: No limit. 1: Limit. Hundreds digit: carrier wave modulation system 0: 3 phase modulation. 1: 2 phase and 3 phase modulation. Thousands digit: Asynchronous modulation: Synchronization mode (valid under V/F control) 0: Asynchronous modulation. 1: Synchronous modulation (under 85Hz: Asynchronous modulation).	1	0110	×
F04.11	AVR function	0: No action 1: Action all the time 2: No action only during deceleration	1	0	×
F04.12	Reserved				
F04.13	Auto energy-saving operation	0: No action 1: Action	1	0	×
F04.14	Acceleration time 2 and 1	0.00Hz~upper limit frequency	0.01Hz	0.00Hz	×

## Appendix A EN650A Mini multi-function PMSM Inverter

	switchover frequency				
F04.15	Deceleration time 2 and 1 switchover frequency	0.00Hz~upper limit frequency	0.01Hz	0.00Hz	×
F04.16	Acceleration time 2	1~60000	1	200	○
F04.17	Deceleration time 2	1~60000	1	200	○
F04.18	Acceleration time 3	1~60000	1	200	○
F04.19	Deceleration time 3	1~60000	1	200	○
F04.20	Acceleration time 4	1~60000	1	200	○
F04.21	Deceleration time 4	1~60000	1	200	○
F04.22	Acceleration time 5	1~60000	1	200	○
F04.23	Deceleration time 5	1~60000	1	200	○
F04.24	Acceleration time 6	1~60000	1	200	○
F04.25	Deceleration time 6	1~60000	1	200	○
F04.26	Acceleration time 7	1~60000	1	200	○
F04.27	Deceleration time 7	1~60000	1	200	○
F04.28	Acceleration time 8	1~60000	1	200	○
F04.29	Deceleration time 8	1~60000	1	200	○
F04.30	Acceleration time 9	1~60000	1	200	○
F04.31	Deceleration time 9	1~60000	1	200	○
F04.32	Acceleration time 10	1~60000	1	200	○
F04.33	Deceleration time 10	1~60000	1	200	○
F04.34	Acceleration time 11	1~60000	1	200	○
F04.35	Deceleration time 11	1~60000	1	200	○
F04.36	Acceleration time 12	1~60000	1	200	○
F04.37	Deceleration time 12	1~60000	1	200	○
F04.38	Acceleration time 13	1~60000	1	200	○
F04.39	Deceleration time 13	1~60000	1	200	○
F04.40	Acceleration time 14	1~60000	1	200	○
F04.41	Deceleration time 14	1~60000	1	200	○
F04.42	Acceleration time 15	1~60000	1	200	○
F04.43	Deceleration time 15	1~60000	1	200	○

F05-Communication control parameters group					
Function Code	Name	Set range	Min. Unit	Factory Default	Modification
F05.00	Protocol selection	0:Modbus protocol 1~6:Reserved	1	0	×
F05.01	Baud rate configuration	Units digit: Modbus Baud rate selection 0:300BPS 1:600BPS 2:1200BPS 3:2400BPS 4:4800BPS 5:9600BPS 6:19200BPS 7:38400BPS 8:57600BPS Tens digit: Reserved	1	005	×

## Appendix A EN650A Mini multi-function PMSM Inverter

		Hundreds digit: Reserved			
F05.02	Data format	Units digit: Modbus protocol data format 0:1-8-1 format, no parity, RTU 1:1-8-1 format, even parity, RTU 2:1-8-1 format, odd parity, RTU 3:1-7-1 format, no parity, ASCII 4:1-7-1 format, even parity, ASCII 5:1-7-1 format, odd parity, ASCII Tens digit: Reserved		00	×
F05.03	Local address	0~247, For Modbus protocol, 0 is broadcast address which just receive and execute the command from upper computer without response;; For free protocol, 0 is the address of master.	1	1	×
F05.04	Communication overtime checkout time	0.0~1000.0s	0.1s	0.0s	○
F05.05	Communication error checkout time	0.0~1000.0s	0.1s	0.0s	○
F05.06	Local response delay time	0~200ms (Modbus valid)	1ms	5ms	○
F05.07	Master & slave inverter communication frequency setting percentage	0~500%	1%	100%	○
F05.08	Communication virtual input terminal Enabled.	00~FFH Bit0: CX1 virtual input terminal Enabled. 0: Forbidden 1: Enabled Bit1: CX2 virtual input terminal Enabled. 0: Forbidden 1: Enabled. Bit2: CX3 virtual input terminal Enabled. 0: Forbidden 1: Enabled. Bit3: CX4 virtual input terminal Enabled. 0: Forbidden 1: Enabled. Bit4: CX5 virtual input terminal Enabled. 0: Forbidden 1: Enabled. Bit5: CX6 virtual input terminal Enabled. 0: Forbidden 1: Enabled. Bit6: CX7 virtual input terminal Enabled. 0: Forbidden 1: Enabled. Bit7: CX8 virtual input terminal Enabled. 0: Forbidden 1: Enabled.	1	00H	○
F05.09	Communication virtual input terminal joining node	0: Independent node. 1: Terminal node.	1	0	○
F05.10	Communication virtual terminal CX1 function	0~90	1	0	○
F05.11	Communication virtual terminal CX2 function	0~90	1	0	○
F05.12	Communication virtual terminal CX3 function	0~90	1	0	○
F05.13	Communication virtual	0~90	1	0	○

## Appendix A EN650A Mini multi-function PMSM Inverter

	terminal CX4 function				
F05.14	Communication virtual terminal CX5 function	0~90	1	0	○
F05.15	Communication virtual terminal CX6 function	0~90	1	0	○
F05.16	Communication virtual terminal CX7 function	0~90	1	0	○
F05.17	Communication virtual terminal CX8 function	0~90	1	0	○
F05.18	Input mapping application parameter 1	F00.00~F26.xx	0.01	25.00	○
F05.19	Input mapping application parameter 2	F00.00~F26.xx	0.01	25.00	○
F05.20	Input mapping application parameter 3	F00.00~F26.xx	0.01	25.00	○
F05.21	Input mapping application parameter 4	F00.00~F26.xx	0.01	25.00	○
F05.22	Input mapping application parameter 5	F00.00~F26.xx	0.01	25.00	○
F05.23	Input mapping application parameter 6	F00.00~F26.xx	0.01	25.00	○
F05.24	Input mapping application parameter 7	F00.00~F26.xx	0.01	25.00	○
F05.25	Input mapping application parameter 8	F00.00~F26.xx	0.01	25.00	○
F05.26	Input mapping application parameter 9	F00.00~F26.xx	0.01	25.00	○
F05.27	Input mapping application parameter 10	F00.00~F26.xx	0.01	25.00	○
F05.28 ~ F05.39	Reserved				

### F06—Setting curve parameter group

Function Code	Name	Set range	Min. Unit	Factory Default	Modification
F06.00	Setting curve selection	Units digit: A11 curve selection 0: curve 1 1: curve 2 2: curve 3 Tens digit: A12 curve selection: The same as Units digit Hundred digit: Rapid pulse curve selection: Same as Units digit Thousands digit: Pulse width setting curve selection: Same as Units digit	1	0000	○
F06.01	Curve 1 min. setting	0.0%~curve 1 inflexion setting	0.1%	0.0%	○
F06.02	Corresponding physical quantity of curve 1 min.	0.0~100.0%	0.1%	0.0%	○

## Appendix A EN650A Mini multi-function PMSM Inverter

	setting				
F06.03	Curve 1 inflexion setting	Curve 1 min. setting ~ curve 1 Max. setting	0.1%	50.0%	○
F06.04	Corresponding physical quantity of curve 1 inflexion setting	0.0~100.0%	0.1%	50.0%	○
F06.05	Curve 1 Max. setting	Curve 1 inflexion setting ~ 100.0%, 100.0% is corresponding to 5V Input AD terminal	0.1%	100.0%	○
F06.06	Corresponding physical quantity of curve 1 Max. setting	0.0~100.0%	0.1%	100.0%	○
F06.07	Curve 2 min. setting	0.0%~curve 2 inflexion setting	0.1%	0.0%	○
F06.08	Corresponding physical quantity of curve 2 min. setting	0.0~100.0%	0.1%	0.0%	○
F06.09	Curve 2 inflexion setting	Curve 2 min. setting ~ curve 2 Max. setting	0.1%	50.0%	○
F06.10	Corresponding physical quantity of curve 2 inflexion setting	0.0~100.0%	0.1%	50.0%	○
F06.11	Curve 2 Max. setting	Curve 2 inflexion setting~100.0%	0.1%	100.0%	○
F06.12	Corresponding physical quantity of curve 2 Max. setting	0.0~100.0%	0.1%	100.0%	○
F06.13	Curve 3 min. setting	0.0%~curve 3 inflexion 1 setting	0.1%	0.0%	○
F06.14	Corresponding physical quantity of curve 3 min. setting	0.0~100.0%	0.1%	0.0%	○
F06.15	Curve 3 inflexion 1 setting	Curve 3 min. setting ~ curve 3 inflexion 2 setting	0.1%	30.0%	○
F06.16	Corresponding physical quantity of curve 3 inflexion 1 setting	0.0~100.0%	0.1%	30.0%	○
F06.17	Curve 3 inflexion 2 setting	Curve 3 inflexion 1 setting ~ curve 3 Max. setting	0.1%	60.0%	○
F06.18	Corresponding physical quantity of curve 3 inflexion 2 setting	0.0~100.0%	0.1%	60.0%	○
F06.19	Curve 3 Max. setting	Curve 3 inflexion 1 setting~100.0%	0.1%	100.0%	○
F06.20	Corresponding physical quantity of curve 3 Max. setting	0.0~100.0%	0.1%	100.0%	○
F06.21	Curve lower than min. input corresponding selection	Units digit: curve 1 setting 0: Corresponds to min. setting corresponding physical quantity. 1: 0.0% of the corresponding physical quantity. Tens digit: curve 2 setting: Same as Units digit. Hundreds digit: curve 3 setting: Same as Units digit.	1	11111	○

## Appendix A EN650A Mini multi-function PMSM Inverter

		Thousands digit: extended curve 1 Same as Units digit. Ten thousands digit: extended curve 2: Same as Units digit.			
--	--	---	--	--	--

### F07-Analog , Pulse input function parameters group

Function Code	Name	Set range	Min. Unit	Factory Default	Modification
F07.00	A11 input filter time	0.000~9.999s	0.001s	0.050s	×
F07.01	A11 setting gain	0.000~9.999	0.001	1.004	○
F07.02	A11 setting bias	0.0~100.0%	0.1%	0.5%	○
F07.03	A12 input filter time	0.000~9.999s	0.001	0.050s	×
F07.04	A12 setting gain	0.000~9.999	0.001	1.003	○
F07.05	A12 setting bias	0.0~100.0%	0.1%	0.1%	○
F07.06	Analog setting bias polarity	units digit: A11 setting bias polarity 0: Positive polarity. 1: Negative polarity. tens digit: A12 setting bias polarity 0: Positive polarity. 1: Negative polarity.	1	01	○
F07.07	Pulse input filter time	0.000~9.999s	0.001	0.000s	×
F07.08	Pulse input gain	0.000~9.999	0.001	1.000	○
F07.09	Pulse input Max. frequency	0.01~50.00KHz	0.01KHz	10.00KHz	○
F07.10	Pulse width input filter time	0.000~9.999s	0.001s	0.000s	×
F07.11	Pulse width input gain	0.000~9.999	0.001	1.000	○
F07.12	Pulse width input logic setting.	0:positive logic 1:negative logic	1	0	○
F07.13	Max pulse input width	0.1~999.9ms	0.1ms	100.0ms	○
F07.14 ~ F07.17	Reserved				

### F08-On-off input function parameter group

Function Code	Name	Set range	Min. Unit	Factory Default	Modification
F08.00	Input terminal positive and negative logic setting	0000~FFFF (Include extend input terminal)	1	0000	○
F08.01	Input terminal filter time	0.000~1.000s (Suitable for extend input terminal)	0.001s	0.010s	○
F08.02	X1 Input terminal closed time	0.00~99.99s	0.01s	0.00s	○
F08.03	X1 Input terminal opened time	0.00~99.99s	0.01s	0.00s	○
F08.04	X2 Input terminal closed time	0.00~99.99s	0.01s	0.00s	○



## Appendix A EN650A Mini multi-function PMSM Inverter

F08.05	X2 Input terminal opened time	0.00~99.99s	0.01s	0.00s	○
F08.06	X3 Input terminal closed time	0.00~99.99s	0.01s	0.00s	○
F08.07	X3 Input terminal opened time	0.00~99.99s	0.01s	0.00s	○
F08.08	X4 Input terminal closed time	0.00~99.99s	0.01s	0.00s	○
F08.09	X4 Input terminal opened time	0.00~99.99s	0.01s	0.00s	○
F08.10	X5 Input terminal closed time	0.00~99.99s	0.01s	0.00s	○
F08.11	X5 Input terminal opened time	0.00~99.99s	0.01s	0.00s	○
F08.12	X6 Input terminal closed time	0.00~99.99s	0.01s	0.00s	○
F08.13	X6 Input terminal opened time	0.00~99.99s	0.01s	0.00s	○
F08.14	X7 Input terminal closed time	0.00~99.99s	0.01s	0.00s	○
F08.15	X7 Input terminal opened time	0.00~99.99s	0.01s	0.00s	○
F08.16	Reserved				
F08.17	Reserved				
F08.18	Input terminal X1 function selection	0:Leave control terminal unused 1:Forward running FWD terminal 2:Reverse running REV terminal 3:External forward jogging control 4:External reverse jogging control 5:Multi-step speed control terminal 1 6:Multi-step speed control terminal 2 7:Multi-step speed control terminal 3 8:Multi-step speed control terminal 4 9:Acc/Dec time selection terminal 1 10:Acc/Dec time selection terminal 2 11:Acc/Dec time selection terminal 3 12:Acc/Dec time selection terminal 4 13:Main and auxiliary frequency operational rule selection terminal 1 14:Main and auxiliary frequency operational rule selection terminal 2 15:Main and auxiliary frequency operational rule selection terminal 3 16:Frequency ascending command (UP) 17:Frequency descending command (DOWN) 18:Reset ascend and descend frequency 19:Multi-step closed loop terminal 1 20:Multi-step closed loop terminal 2 21:Multi-step closed loop terminal 3 22:External equipment failure input 23:External interruption input	1	1	×

		<p>24: External resetting input</p> <p>25: Free stop input</p> <p>26: External stop instruction—Stop according to the stop mode</p> <p>27: Stop DC braking input command DB</p> <p>28: Inverter running prohibited—Stop according to the stop mode</p> <p>29: Acceleration/deceleration prohibited command</p> <p>30: Three-wire running control</p> <p>31: Process PID invalid</p> <p>32: Process PID stop</p> <p>33: Process PID integral holding</p> <p>34: Process PID integral resetting</p> <p>35: Process PID function negation(Closed loop adjustment feature negation)</p> <p>36: Simple PLC invalid</p> <p>37: Simple PLC halted</p> <p>38: Simple PLC stop state resetting</p> <p>39: Main frequency switchover to digit (keypad)</p> <p>40: Main frequency switchover to AI1</p> <p>41: Main frequency switchover to AI2</p> <p>42: Main frequency switchover to EAI1</p> <p>43: Main frequency switchover to EAI2</p> <p>44: Main frequency setting channel selection terminal 1</p> <p>45: Main frequency setting channel selection terminal 2</p> <p>46: Main frequency setting channel selection terminal 3</p> <p>47: Main frequency setting channel selection terminal 4</p> <p>48: Auxiliary frequency reset</p> <p>49: Command switchover to panel</p> <p>50: Command switchover to terminal</p> <p>51: Command switchover to communication</p> <p>52: Running command Channel selection terminal 1</p> <p>53: Running command Channel selection terminal 2</p> <p>54: Forward prohibited command (Stop according to the stop mode: invalid for jogging command)</p> <p>55: Reverse prohibited command (Stop according to the stop mode: invalid for jogging command)</p> <p>56: Swinging frequency input</p> <p>57: Resetting state of swinging frequency</p> <p>58: Interior counter reset end</p> <p>59: Interior counter input end</p>			
--	--	--	--	--	--

## Appendix A EN650A Mini multi-function PMSM Inverter

		60:Internal timer resetting 61:Internal timer triggering 62:Length count input 63:Length reset 64:Reset this operation time 65: Speed/torque control switching (PMSM valid) 66~90:Reserved 91:Pulse frequency input (X7 VALID) 92:Pulse width PWM INPUT (X7 VALID) 93~96:Reserved			
F08.19	Input terminal X2 function selection	Same as above	1	2	×
F08.20	Input terminal X3 function selection	Same as above	1	0	×
F08.21	Input terminal X4 function selection	Same as above	1	0	×
F08.22	Input terminal X5 function selection	Same as above	1	0	×
F08.23	Input terminal X6 function selection	Same as above	1	0	×
F08.24	Input terminal X7 function selection	Same as above	1	0	×
F08.25	Reserved				
F08.26	FWD/REV operating mode selection	0:Two-wire control mode 1 1:Two-wire control mode 2 2:Two-wire control mode 3(monopulse control mode) 3:Three-wire control mode 1 4:Three-wire control mode 2	1	0	×
F08.27	Set internal count value to setting	0~65535	1	0	○
F08.28	Specify internal count to setting	0~65535	1	0	○
F08.29	Internal timer timing setting	0.1~6000.0s	0.1	60.0s	○
F08.30	Terminal pulse encoder frequency rate	0.01~10.00Hz (only be effective by given X1:X2 encoder)	0.01Hz	1.00Hz	○
F08.31	Reserved				

### F09-Digital output, analog output function parameter group

Function Code	Name	Set range	Min. Unit	Factory Default	Modification
F09.00	Open collector output terminal Y1 output setup	0:Terminal unused 1:Operation(RUN) 2:Forward run 3:Reverse run 4:DC brake 5:Run prepare finish (DC BUS voltage)	1	0	×

## Appendix A EN650A Mini multi-function PMSM Inverter

		normal, fault free, without run forbid, receivable of run command's status) 6:Stop command indication 7:Zero current detected 8:Overcurrent detected 9:Current1 arrival 10:Current2 arrival 11:No frequency output 12:Frequency arrival signal(FAR) 13:Frequency level detect signal1(FDT1) 14:Frequency level detect signal2(FDT2) 15:Output frequency arrival upper limit(FHL) 16:Output frequency arrival low limit(FLL) 17:Frequency 1 arrival output 18:Frequency 2 arrival output 19:Overload pre-alarm signal(OL) 20: Undervoltage lockout stop (LU) 21:External fault stop(EXT) 22:Fault 23:Alarm 24:Simple PLC operation 25:Simple PLC section operation finish 26:Simple PLC circle operation finish 27:Simple PLC operation stop 28:Reverse frequency high and low limit 29:Setup length arrival 30:Internal counter final value arrival 31:Internal counter designated value arrival 32:Internal timer arrival---output 0.5s valid signal on arrival 33:Operation stop time finish 34:Operation arrival time finish 35:Setup run time arrival 36:Setup power on time arrival 37~40:Reserved 41: Communication provision 42~60: Reserved			
F09.01	Open collector output terminal Y2 output setup	Same as above	1	0	×
F09.02	Reserved				
F09.03	Reserved				
F09.04	Programmable relay output setup	Same as above	1	22	×
F09.05	Frequency arrival (FAR) detection range	0.00~50.00Hz	0.01Hz	5.00Hz	○
F09.06	FDT (frequency level)level	0.00Hz~Upper limit Fre.	0.01Hz	10.00Hz	○
F09.07	FDT1 lag	0.00~50.00Hz	0.01Hz	1.00Hz	○
F09.08	FDT2 (frequency level)	0.00Hz~Upper limit Fre.	0.01	10.00Hz	○

## Appendix A EN650A Mini multi-function PMSM Inverter

	level		Hz		
F09.09	FDT2 lag	0.00~50.00Hz	0.01Hz	1.00Hz	○
F09.10	Zero frequency signal detection value	0.00Hz~Upper limit Fre.	0.01Hz	0.00Hz	○
F09.11	Zero frequency return difference	0.00Hz~Upper limit Fre.	0.01 Hz	0.00Hz	○
F09.12	Zero-current detection range	0.0~50.0%	0.1%	0.0%	○
F09.13	Zero-current detection time	0.00~60.00s	0.01s	0.1s	○
F09.14	Over-current detection value	0.0~250.0%	0.1%	160.0%	○
F09.15	Over-current detection time	0.00~60.00s	0.01s	0.00s	○
F09.16	Current 1 arrival detection value	0.0~250.0%	0.1%	100.0%	○
F09.17	Current 1 width	0.0~100.0%	0.1%	0.0%	○
F09.18	Current 2 arrival detection value	0.0~250.0%	0.1%	100.0%	○
F09.19	Current 2 width	0.0~100.0%	0.1%	0.0%	○
F09.20	Frequency 1 arrival detection value	0.00Hz~Upper limit Fre.	0.01 Hz	50.00Hz	○
F09.21	Frequency 1 arrival detection width	0.00Hz~Upper limit Fre.	0.01Hz	0.00Hz	○
F09.22	Frequency 2 arrival detection value	0.00Hz~Upper limit Fre.	0.01Hz	50.00Hz	○
F09.23	Frequency 2 arrival detection width	0.00Hz~Upper limit Fre.	0.01Hz	0.00Hz	○
F09.24	Output terminal positive and negative logic setup	0000~FFFF	1	0000	○
F09.25	Y1 output close delay time	0.000~50.000s	0.001s	0.000s	○
F09.26	Y1 output open delay time	0.000~50.000s	0.001s	0.000s	○
F09.27	Y2 output close delay time	0.000~50.000s	0.001s	0.000s	○
F09.28	Y2 output open delay time	0.000~50.000s	0.001s	0.000s	○
F09.29 ~ F09.32	Reserved				
F09.33	Relay output close delay time	0.000~50.000s	0.001s	0.000s	○
F09.34	Relay output turn-off delay time	0.000~50.000s	0.001s	0.000s	○
F09.35	Analog output(AO1)	0:Output frequency before slip compensation (0.00Hz~upper limit frequency) 1:Output frequency after slip compensation (0.00Hz~upper limit frequency) 2:Setup frequency (0.00Hz~upper limit frequency) 3:Main setting frequency (0.00Hz~upper limit frequency)	1	0	○

## Appendix A EN650A Mini multi-function PMSM Inverter

		4:Auxiliary setting Frequency (0.00Hz~upper limit frequency) 5:Output current 1(0~2×inverter rated current) 6:Output current 2(0~3×motor rated current) 7:Output voltage (0~1.2×load motor rated voltage) 8:Busbar voltage (0~1.5×rated busbar voltage) 9:Motor speed (0~3 rated speed) 10:PID provision (0.00~10.00V) 11:PID feedback (0.00~10.00V) 12:A11 (0.00~10.00V or 4~20mA) 13:A12 (-10.00~10.00V or 4~20mA) 14:Communication provision 15~25:Reserved			
F09.36	Reserved				
F09.37	DO function selection (With Y4 reuse)	Same as above	1	0	○
F09.38	Reserved				
F09.39	Analog output(AO1) filter time	0.0~20.0s	0.1s	0.0s	○
F09.40	Analog output(AO1) gain	0.00~2.00	0.01	1.00	○
F09.41	Analog output(AO1) bias	0.0~100.0%	0.1%	0.0%	○
F09.42 ~ F09.44	Reserved				
F09.45	DO filter time	0.0~20.0s	0.1s	0.0s	○
F09.46	DO output gain	0.00~2.00	0.01	1.00	○
F09.47	DO maximum pulse output frequency	0.1~20.0KHz	0.1 KHz	10.0KHz	○
F09.48 ~ F09.50	Reserved				

### F10-Simple PLC/Multi-speed Function Parameter Group

Function Code	Name	Set range	Min. Unit	Factory Default	Modification
F10.00	Simple PLC run setup	Units digit: run mode selection 0:Inaction 1:Stop after single cycle 2:Final value keep after single cycle 3:Continuous cycle Tens digit: Interrupt run restart mode selection 0:Restart from first phase 1:Continuous run from phase frequency	1	0000	×

		at interruption 2: Continuous run from run frequency at interruption Hundreds digit: PLC run time unit 0: Second 1: Minute Thousands digit: power-down memory selection 0: No memory 1: Phase of reserve power down, frequency power down recording PLC run status: contain power down phase, run frequency, time have run.			
F10.01	Step1 setup	000H~E22H Units digit: frequency setup 0: Multi-section frequency i (i=1~15) 1: frequency determined by complex frequency of main and auxiliary 2: Reserved Tens digit: operation direction selection 0: Forward 1: Reversal 2: Determine by run command Hundreds digit: ACC/DEC time selection 0: ACC/DEC time 1 1: ACC/DEC time 2 2: ACC/DEC time 3 3: ACC/DEC time 4 4: ACC/DEC time 5 5: ACC/DEC time 6 6: ACC/DEC time 7 7: ACC/DEC time 8 8: ACC/DEC time 9 9: ACC/DEC time 10 A: ACC/DEC time 11 B: ACC/DEC time 12 C: ACC/DEC time 13 D: ACC/DEC time 14 E: ACC/DEC time 15	1	000	○
F10.02	Step 2 setup	000H~E22H	1	000	○
F10.03	Step 3 setup	000H~E22H	1	000	○
F10.04	Step 4 setup	000H~E22H	1	000	○
F10.05	Step 5 setup	000H~E22H	1	000	○
F10.06	Step 6 setup	000H~E22H	1	000	○
F10.07	Step 7 setup	000H~E22H	1	000	○
F10.08	Step 8 setup	000H~E22H	1	000	○
F10.09	Step 9 setup	000H~E22H	1	000	○
F10.10	Step 10 setup	000H~E22H	1	000	○
F10.11	Step 11 setup	000H~E22H	1	000	○
F10.12	Step 12 setup	000H~E22H	1	000	○

## Appendix A EN650A Mini multi-function PMSM Inverter

F10.13	Step 13 setup	000H~E22H	1	000	○
F10.14	Step 14 setup	000H~E22H	1	000	○
F10.15	Step 15 setup	000H~E22H	1	000	○
F10.16	Step 1 run time	0~6000.0	0.1	10.0	○
F10.17	Step 2 run time	0~6000.0	0.1	10.0	○
F10.18	Step 3 run time	0~6000.0	0.1	10.0	○
F10.19	Step 4 run time	0~6000.0	0.1	10.0	○
F10.20	Step 5 run time	0~6000.0	0.1	10.0	○
F10.21	Step 6 run time	0~6000.0	0.1	10.0	○
F10.22	Step 7 run time	0~6000.0	0.1	10.0	○
F10.23	Step 8 run time	0~6000.0	0.1	10.0	○
F10.24	Step 9 run time	0~6000.0	0.1	10.0	○
F10.25	Step 10 run time	0~6000.0	0.1	10.0	○
F10.26	Step 11 run time	0~6000.0	0.1	10.0	○
F10.27	Step 12 run time	0~6000.0	0.1	10.0	○
F10.28	Step 13 run time	0~6000.0	0.1	10.0	○
F10.29	Step 14 run time	0~6000.0	0.1	10.0	○
F10.30	Step 15 run time	0~6000.0	0.1	10.0	○
F10.31	Multi-speed frequency 1	0.00Hz~upper limit Fre.	0.01Hz	5.00Hz	○
F10.32	Multi-speed frequency 2	0.00Hz~upper limit Fre.	0.01Hz	10.00Hz	○
F10.33	Multi-speed frequency 3	0.00Hz~upper limit Fre.	0.01Hz	20.00Hz	○
F10.34	Multi-speed frequency 4	0.00Hz~upper limit Fre.	0.01Hz	30.00Hz	○
F10.35	Multi-speed frequency 5	0.00Hz~upper limit Fre.	0.01Hz	40.00Hz	○
F10.36	Multi-speed frequency 6	0.00Hz~upper limit Fre.	0.01Hz	45.00Hz	○
F10.37	Multi-speed frequency 7	0.00Hz~upper limit Fre.	0.01Hz	50.00Hz	○
F10.38	Multi-speed frequency 8	0.00Hz~upper limit Fre.	0.01Hz	5.00Hz	○
F10.39	Multi-speed frequency 9	0.00Hz~upper limit Fre.	0.01Hz	10.00Hz	○
F10.40	Multi-speed frequency 10	0.00Hz~upper limit Fre.	0.01Hz	20.00Hz	○
F10.41	Multi-speed frequency 11	0.00Hz~upper limit Fre.	0.01Hz	30.00Hz	○
F10.42	Multi-speed frequency 12	0.00Hz~upper limit Fre.	0.01Hz	40.00Hz	○
F10.43	Multi-speed frequency 13	0.00Hz~upper limit Fre.	0.01Hz	45.00Hz	○
F10.44	Multi-speed frequency 14	0.00Hz~upper limit Fre.	0.01Hz	50.00Hz	○
F10.45	Multi-speed frequency 15	0.00Hz~upper limit Fre.	0.01Hz	50.00Hz	○

### F11-Close-loop PID run function parameter group

Function Code	Name	Set range	Min. Unit	Factory Default	Modification
F11.00	Close-loop run control selection	0:PID close loop run control invalid 1:PID close loop run control valid	1	0	×
F11.01	Provide channel selection	0:digital provide 1:A11 analog provide 2:A12 analog provide 3:Reserved 4:Reserved 5:Pulse provide 6:Communication provide 7: Reserved 8: Reserved	1	0	○



## Appendix A EN650A Mini multi-function PMSM Inverter

F11.02	Feedback channel selection	0:A11 analog input 1:A12 analog input 2: Reserved 3: Reserved 4:A11+A12 5:A11-A12 6:Min {A11, A12} 7:Max {A11, A12} 8: pulse input	1	0	○
F11.03	Provide channel filtering time	0.01~50.00s	0.01s	0.20s	×
F11.04	Feedback channel filtering time	0.01~50.00s	0.01s	0.10s	×
F11.05	PID output filtering time	0.00~50.00s	0.01s	0.00s	○
F11.06	Provide digital setup	0.00~10.00V	0.01V	1.00V	○
F11.07	Proportional gain Kp	0.000~9.999	0.001	0.150	○
F11.08	Integral gain Ki	0.000~9.999	0.001	0.150	○
F11.09	Differential gain Kd	0.000~9.999	0.001	0.000	○
F11.10	Sample period T	0.01~1.00s	0.01s	0.10s	○
F11.11	Deviation range	0.0~20.0% correspond to provide value percentage	0.1%	2.0%	○
F11.12	PID differential range	0.00~100.00%	0.01%	0.10%	○
F11.13	Close-loop adjust characteristic	0:Positive 1:Negative	1	0	○
F11.14	Feedback channel plus-minus characteristic	0: Positive characteristic 1: Negative characteristic	1	0	○
F11.15	PID adjusting upper limit frequency	Low limit Fre.~upper limit Fre.	0.01Hz	50.00Hz	○
F11.16	PID adjusting low limit frequency	Low limit Fre.~upper limit Fre.	0.01Hz	0.00Hz	○
F11.17	Integral adjusting selection	0:When integral arrival separate PID threshold value, stop integral adjusting 1:When integral arrival separate PID threshold value, continue integral adjusting	1	0	○
F11.18	Integral separate PID threshold value	0.0~100.0%	0.1%	100.0%	○
F11.19	Close-loop preset frequency	Low limit Fre.~upper limit Fre.	0.01Hz	0.00Hz	○
F11.20	Close-loop preset frequency keep time	0.0~6000.0s	0.1s	0.0s	○
F11.21	Close-loop output changeover selection	0:Close-loop negative output ,low limit Fre. run. 1:Close-loop negative output, reverse run (Effect by run direction setting )	1	0	○
F11.22	Close-loop output frequency maximum value	0.00Hz~Upper limit Fre.	0.01Hz	50.00Hz	○

## Appendix A EN650A Mini multi-function PMSM Inverter

F11.23	Multi-section close-loop provision 1	0.00~10.00V	0.01V	0.00V	○
F11.24	Multi-section close-loop provision 2	0.00~10.00V	0.01V	0.00V	○
F11.25	Multi-section close-loop provision 3	0.00~10.00V	0.01V	0.00V	○
F11.26	Multi-section close-loop provision 4	0.00~10.00V	0.01V	0.00V	○
F11.27	Multi-section close-loop provision 5	0.00~10.00V	0.01V	0.00V	○
F11.28	Multi-section close-loop provision 6	0.00~10.00V	0.01V	0.00V	○
F11.29	Multi-section close-loop provision 7	0.00~10.00V	0.01V	0.00V	○

### F12-Reserved parameters group 1

Function code	Name	Set range	Min. unit	Factory Default	Modification
F12.00 ~ F12.14	Reserved				

### F13-Traversal/Fixed Length Control Function Parameter Group

Function code	Name	Set range	Min. unit	Factory Default	Modification
F13.00	Traversal function enable	0:Traversal invalid 1:Traversal valid	1	0	×
F13.01	Traversal run mode	Units digit: enter mode 0:Automatically enter 1:Terminal enter manually Tens digit: 0:Variable swing 1:Fixed swing Hundreds digit: traversal halt start mode selection 0:Restart 1:Start as previous halt record Thousands digit: traversal status reserve selection 0:No reserve 1:Reserve	1	0000	×
F13.02	Traversal frequency swing value	0.0~50.0%	0.1%	10.0%	○
F13.03	Jump frequency	0.0~50.0%	0.1%	2.0%	○
F13.04	Traversal cycle	0.1~999.9s	0.1s	10.0s	○
F13.05	Triangular wave up time	0.0~98.0% (traversal cycle)	0.1%	50.0%	○
F13.06	Traversal preset frequency	0.00~400.00Hz	0.01Hz	0.00Hz	○

## Appendix A EN650A Mini multi-function PMSM Inverter

F13.07	Traverse preset frequency waiting time	0.0~6000.0s	0.1s	0.0s	○
F13.08	Setup length	0~65535m	1m	0m	○
F13.09	Pulse No. of axis per circle	1~10000	1	1	○
F13.10	Axis perimeter	0.01~100.00cm	0.01cm	1000cm	○
F13.11	Reserved				
F13.12	Length correction coefficient	0.001~1.000	0.001	1.000	○
F13.13	After length arrival: record length manage	0:Automatically reset 1:No change	0	1	○
F13.14	When stop: record length manage	0:Automatically reset 1:No change	0	1	○

### F14-Reserved parameters group 2

Function code	Name	Set range	Min. unit	Factory Default	Modification
F14.00 ~ F14.25	Reserved				

### F15-Motor parameters group 1

Function code	Name	Set range	Min. unit	Factory Default	Modification
F15.00	Motor rated power	0.1~999.9KW	0.1KW	Base on motor	×
F15.01	Motor rated voltage	1~690V	1V	Base on motor	×
F15.02	Motor rated current	0.1~6553.5A	0.1A	Base on motor	×
F15.03	Motor rated frequency	0.00~400.00Hz	0.01Hz	Base on motor	×
F15.04	Motor rated speed	0~60000r/min	1r/min	Base on motor	×
F15.05	Motor pole pairs.	1~80	1	2	×
F15.06	Asynchronous motor stator resistance	0.0000~6.5535Ω	0.0001	Base on motor	×
F15.07	Asynchronous motor rotor resistance	0.000~6.5535Ω	0.0001	Base on motor	×
F15.08	Asynchronous motor leakage inductance	0.00~655.35 mH	0.01 mH	Base on motor	×
F15.09	Asynchronous motor mutual inductance	0.00~655.35 mH	0.01m H	Base on motor	×
F15.10	Asynchronous motor non-load current	0.01~655.35A	0.01A	Base on motor	×
F15.11	Motor parameters self-learning	0:No action 1:Asynchronous motor static self-learning 2:Asynchronous motor rotate self-learning	1	0	×

		without load 3:Reserved			
--	--	----------------------------	--	--	--

F16-Vector control parameters group					
Function code	Name	Set range	Min. Unit	Factory Default	Modification
F16.00	PMSM speed/torque control selection	0:Speed control 1:Torque control	1	0	×
F16.01	PMSM speed-loop high speed proportion gain	0.0~200.0	0.1	20.0	○
F16.02	PMSM speed-loop high speed integration time	0.000~10.000s	0.001s	1.000s	○
F16.03	PMSM speed-loop low speed proportion gain	0.0~200.0	0.1	20.0	○
F16.04	PMSM speed-loop low speed integration time	0.000~10.000s	0.001s	1.000s	○
F16.05	PMSM speed-loop switching Fre. 1	0.00Hz~F16.06	0.01 Hz	5.00 Hz	○
F16.06	PMSM speed-loop switching Fre. 2	F16.05~F01.11	0.01 Hz	10.00 Hz	○
F16.07	PMSM speed-loop filter time	0.0~500.0ms	0.1ms	0.3ms	○
F16.08	PMSM flux-weakening proportion gain	0.0~200.0	0.1	50.0	○
F16.09	PMSM current-loop proportion gain	0.000~5.000	0.001	0.650	○
F16.10	PMSM current-loop integration time	0.000~5.000	0.001	0.150	○
F16.11	PMSM torque control direction setup	0:Forward direction 1:Reverse direction	1	0	○
F16.12	PMSM torque provision channel selection	0:Digital setting provision 1:A11 Analog provision 2:A12 Analog provision 3:Terminal UP/DOWN adjustment setting 4:communication provision(Same memory for Modbus and external field bus) 5:Reserved 6: Reserved 7:Rapid pulse setting (Select X7 as matched function) 8: Reserved 9:Multi-speed provision (Using multi-speed function, upper limit Fre. correspond with 200% rated torque) 10: Reserved	1	0	×
F16.13	PMSM torque control digital setup	0.0~200.0%	0.1%	20.0%	○
F16.14	Electric torque digital limitation under speed	0.0~200.0%	0.1%	180.0%	×

## Appendix A EN650A Mini multi-function PMSM Inverter

	control mode				
F16.15	Braking torque digital limitation under speed control mode	0.0~200.0%	0.1%	180.0%	×
F16.16	Forward speed limitation (PMSM torque control)	0.00Hz~F01.11	0.01Hz	50.00Hz	×
F16.17	Reverse speed limitation (PMSM torque control)	0.00Hz~F01.11	0.01Hz	50.00Hz	×
F16.18	PMSM pole detection current coefficient	1~50	1	5	×
F16.19	PMSM initial pole position detection selection	0:No detect 1:Adopt impulse response detection 2:Adopt forced return to Zero detection	1	1	×
F16.20	PMSM pull-in current 1	0.0~100.0%	0.1%	20.0%	×
F16.21	PMSM pull-in current 2	0.0~100.0%	0.1%	10.0%	×
F16.22	PMSM pull-in current switching frequency	5.00Hz~F01.11	0.01Hz	10.00Hz	×
F16.23	PMSM compensation coefficient at low frequency	0~50	1	30	×
F16.24	PMSM pre-excitation time	0.000s~5.000s	0.001s	0.300s	×
F16.25	PMSM field weakening coefficient	0.0~2.0	0.1	0.3	×
F16.26	Asynchronous motor speed-loop proportional gain	0.010~6.000	0.001	0.700	○
F16.27	Asynchronous motor speed-loop integral time constant	0.010~9.999	0.001	0.360	○
F16.28	Asynchronous motor compensation gain of vibration restrain	100.0~130.0%	0.1%	100.0%	○
F16.29	Asynchronous motor stabilization coefficient	10~300	1	100	○

### F17-Motor parameters group 2

Function code	Name	Set range	Min. Unit	Factory Default	Modification
F17.00	PMSM stator resistance	0.000~65.535Ω	0.001Ω	Base on motor	○
F17.01	PMSM direct-axis inductance	0.00~655.35mH	0.01 mH	Base on motor	○
F17.02	PMSM q-axis inductance	0.00~655.35mH	0.01 mH	Base on motor	○
F17.03	PMSM back electromotive force constant	0~10000	1	Base on motor	○

## Appendix A EN650A Mini multi-function PMSM Inverter

F17.04	Encode line number	1~10000	1	1024	×
F17.05	Encoder AB sequence	0:Forward direction 1:Reverse direction	1	0	×
F17.06	Encoder installation angle	0.0~359.9°	0.1°	0.0°	×
F17.07	Encoder filtering coefficient	5~100	1	15	○
F17.08 ~ F17.20	Reserved				

### F18-Enhance Control Parameter Group

Function code	Name	Set range	Min. Unit	Factory Default	Modification
F18.00	Operation panel control frequency binding	0:No binding 1:Operation keyboard digital setup 2:A11 analog setup 3:A12 analog setup 4:Terminal UP/DOWN adjusting setup 5:Communication provide 6:Reserved 7:Reserved 8:High speed pulse setup(Select X7 as matched function) 9:Terminal pulse width setup(Select X7 as matched function) 10: Terminal encoder provision (Definite by X1, X2) 11~15:Reserved	1	0	○
F18.01	Terminal control frequency binding	Same as above	1	0	○
F18.02	Communication control frequency binding	Same as above	1	0	○
F18.03	Digital frequency integral function selection	Units digit: keyboard UP/DW integral control 0:Integral function 1:No integral function Tens digit: terminal UP/DW integral control 0:Integral function 1:No integral function	1	00	○
F18.04	Keyboard UP/DW integral rate	0.01~50.00Hz	0.01Hz	0.10Hz	○
F18.05	Keyboard no integral single step's size setup	0.01~10.00Hz	0.01 Hz	0.01Hz	○
F18.06	Terminal UP/DW integral rate	0.01~50.00Hz	0.01 Hz	0.20Hz	○
F18.07	Terminal no integral single step's size setup	0.01~10.00Hz	0.01 Hz	0.10Hz	○

## Appendix A EN650A Mini multi-function PMSM Inverter

F18.08	Droop control decline frequency	0.00~10.00Hz	0.01 Hz	0.00Hz	○
F18.09	Setup accumulate power on time	0~65535 h	1	0	○
F18.10	Setup accumulate run time	0~65535 h	1	0	○
F18.11	Setup run function enable	0:Invalid 1:Valid	1	0	○
F18.12	Setup run stop time	0.1~6500.0Min	0.1Min	2.0Min	○
F18.13	Currently run arrival time	0.0~6500.0Min	0.1Min	1.0Min	○
F18.14	Keyboard UP/DW selection under monitor mode	0:keyboard frequency provide value adjusting 1:PID digital provide value adjusting 2~6:Reserved	1	0	○
F18.15 ~ F18.24	Reserved				

### F19-Protective Relevant Function Parameter Group

Function code	Name	Set range	Min. Unit	Factory Default	Modification
F19.00	Power off restart waiting time	0.0~20.0s (0 means invalid)	0.1s	0.0s	×
F19.01	Fault self-recovery times	0~10 (0 means the function invalid)	1	0	×
F19.02	Fault self-recovery interval time	0.5~20.0s	0.1s	5.0s	×
F19.03	Motor overload protection action selection	0:Alarm: continuous run 1:Alarm, stop run as halt mode 2:Fault, free halt	1	2	×
F19.04	Motor overload protection coefficient	20.0~200.0% (Motor rated current)	0.1%	100.0%	×
F19.05	Inverter overload pre-alarm detection selection	0:Detection all the time 1:Detection as constant velocity	1	0	×
F19.06	Inverter overload pre-alarm detection level	20~180% (Inverter rated current)	1%	130%	○
F19.07	Inverter overload pre-alarm delay time	0.0~20.0s	0.1s	5.0s	○
F19.08	Motor under-load alarm detection level	0.0~120.0% (Motor rated current)	0.1%	50.0%	○
F19.09	Motor under-load alarm detection time	0.1~60.0s	0.1s	2.0s	○
F19.10	Motor under-load alarm detection action	Units digit: detection selection 0:No detection 1:Detection all the time when run 2:Detection only when constant velocity Tens digit: action selection	1	00	○

## Appendix A EN650A Mini multi-function PMSM Inverter

		0:Alarm, continuous run 1:Alarm, stop run as halt mode 2:Fault, free halt			
F19.11	Input& output phase loss, short circuit detection action	Units digit: input phase loss 0:No detection 1:Fault, free halt Tens digit: output phase loss 0:No detection 1:Fault, free halt Hundreds digit: power-on on earth short circuit protect detection enable 0:No detection 1:Fault, free halt Thousands digit: operation on earth short circuit protect detection enable 0:No detection 1:Fault, free halt	1	1100	○
F19.12	Over voltage stall selection	0:Forbid 1:Allowed	1	1	×
F19.13	Over voltage stall protection voltage	120~150% (Rated DC bus voltage)	1%	125%	×
F19.14	Automatic current limit level	110~200%	1%	150%	×
F19.15	Frequency decline rate of automatic current limit	0.00~99.99Hz/s	0.01 Hz/s	1000 Hz/s	×
F19.16	Automatic current limit action selection	0:Constant velocity invalid 1:Constant velocity valid	1	0	×
F19.17	Reserved				
F19.18	Motor run section selection when instant power off	0:Forbid 1:Allowed	1	0	×
F19.19	Frequency droop rate when instant power off	0.00~99.99Hz/s	0.01 Hz/s	1000 Hz/s	×
F19.20	Voltage rebound estimate time when instant power off	0.00~10.00s	0.01s	0.10s	×
F19.21	Action estimate voltage when instant power off	60~100%(Rated DC bus voltage)	1%	80%	×
F19.22	Allowed the longest off time when instant power off	0.30~5.00s	0.01s	2.00s	×
F19.23	Terminal external device fault action selection	0:Alarm, continuous run 1:Alarm, stop run as halt mode 2:Fault, free halt	1	2	×
F19.24	Power on terminal protection selection	0:Invalid 1:Valid	1	1	×
F19.25	Provide lost detection value	0~100%	1%	0%	○



## Appendix A EN650A Mini multi-function PMSM Inverter

F19.26	Provide lost detection time	0.0~20.0s	0.1s	0.5s	○
F19.27	Feedback lost detection value	0~100%	1%	12%	○
F19.28	Feedback lost detection time	0.0~20.0s	0.1s	0.5s	○
F19.29	Deviation magnitude abnormal detection value	0~100%	1%	50%	○
F19.30	Deviation magnitude abnormal detection time	0.0~20.0s	0.1s	0.5s	○
F19.31	Protection action selection 1	Units digit: PID provide loss detection act 0:No detection 1:Alarm, continue run 2:Alarm, stop run as halt mode 3:Fault, free halt Tens digit: PID feedback loss detection act 0:No detection 1:Alarm, continue run 2:Alarm, stop run as halt mode 3:Fault, free halt Hundreds digit: PID error value abnormal detect action 0:No detection 1:Alarm, continue run 2:Alarm, stop run as halt mode 3:Fault, free halt	1	000	○
F19.32	Protection action selection 2	Units digit: Communication abnormal action: include communication time out and error 0:Alarm, continue run 1:Alarm, stop run as halt mode 2:Fault, free halt Tens digit: E <sup>2</sup> PROM abnormal action selection 0:Alarm, continue run 1:Alarm, stop run as halt mode 2:Fault, free halt Hundreds digit: Contactor abnormal action 0:Alarm, continue run 1:Alarm, stop run as halt mode 2:Fault, free halt Thousands digit: under-voltage fault indication action selection 0:No detection 1:Fault, free halt	1	1200	×
F19.33	Over-speed protection selection	0:Invalid 1:Valid	1	0	×
F19.34	Over-speed protection threshold level	0.00~400.00Hz	0.01Hz	60.00Hz	×

## Appendix A EN650A Mini multi-function PMSM Inverter

F19.35	Fault indication and clock during the period of recovery	Units digit: Fault indication selection during the period of fault reset automatically 0:Action 1:No action Tens digit: Fault clock function selection, to achieve fault display before power down etc. 0:Forbid 1:Open	1	00	×
F19.36	Continuous run frequency selection when alarm	Match up with protect action 0:Run at the frequency setup by now 1:Run at the frequency of upper limit 2:Run at the frequency of low limit 3:Run at the frequency of abnormal for standby	1	0	×
F19.37	Abnormal standby frequency	0.00Hz~Upper limit Fre.	0.01Hz	10.00Hz	×
F19.38 ~ F19.44	Reserved				

### F20-Internal Virtual Input Output Node Parameter Group

Function code	Name	Set range	Min. Unit	Factory Default	Modification
F20.00	Virtual input VDI1 function selection	0~90	1	0	○
F20.01	Virtual input VDI2 function selection	0~90	1	0	○
F20.02	Virtual input VDI3 function selection	0~90	1	0	○
F20.03	Virtual input VDI4 function selection	0~90	1	0	○
F20.04	Virtual input VDI5 function selection	0~90	1	0	○
F20.05	Virtual output VDO1 function selection	0~60	1	0	○
F20.06	Virtual output VDO2 function selection	0~60	1	0	○
F20.07	Virtual output VDO3 function selection	0~60	1	0	○
F20.08	Virtual output VDO4 function selection	0~60	1	0	○
F20.09	Virtual output VDO5 function selection	0~60	1	0	○
F20.10	Virtual output VDO1 open delay time	0.00~600.00s	0.01s	0.00s	○
F20.11	Virtual output VDO2 open delay time	0.00~600.00s	0.01s	0.00s	○
F20.12	Virtual output VDO3 open delay time	0.00~600.00s	0.01s	0.00s	○

## Appendix A EN650A Mini multi-function PMSM Inverter

F20.13	Virtual output VDO4 open delay time	0.00~600.00s	0.01s	0.00s	○
F20.14	Virtual output VDO5 open delay time	0.00~600.00s	0.01s	0.00s	○
F20.15	Virtual output VDO1 close delay time	0.00~600.00s	0.01s	0.00s	○
F20.16	Virtual output VDO2 close delay time	0.00~600.00s	0.01s	0.00s	○
F20.17	Virtual output VDO3 close delay time	0.00~600.00s	0.01s	0.00s	○
F20.18	Virtual output VDO4 close delay time	0.00~600.00s	0.01s	0.00s	○
F20.19	Virtual output VDO5 close delay time	0.00~600.00s	0.01s	0.00s	○
F20.20	Virtual input VDI enable control	00~FF	1	00	○
F20.21	Virtual input VDI status digital setup	00~FF	1	00	○
F20.22	Virtual input/output connection	00~FF Bit0:VDI1 and VDO1 connection 0:Positive logic 1:Negative logic Bit1:VDI2 and VDO2 connection 0:Positive logic 1:Negative logic Bit3:VDI3 and VDO3 connection 0:Positive logic 1:Negative logic Bit4:VDI4 and VDO4 connection 0:Positive logic 1:Negative logic Bit4:VDI5 and VDO5connection 0:Positive logic 1:Negative logic	1	00	○

### F21-Reserved parameters group 3

Function code	Name	Set range	Min. Unit	Factory Default	Modification
F21.00 ~ F21.21	Reserved				

### F22-Reserved parameters group 4

Function code	Name	Set range	Min. Unit	Factory Default	Modification
F22.00 ~ F22.17	Reserved				

F23-Reserved parameters group 5

Function code	Name	Set range	Min. Unit	Factory Default	Modification
F23.00 ~ F23.17	Reserved				

F24-Reserved parameters group 6

Function code	Name	Set range	Min. Unit	Factory Default	Modification
F24.00 ~ F24.13	Reserved				

F25-User Definition Display Parameter Group

Function code	Name	Set range	Min. Unit	Factory Default	Modification
F25.00	User Function Code 1	F00.00~F25.xx	0.01	25.00	○
F25.01	User Function Code 2	F00.00~F25.xx	0.01	25.00	○
F25.02	User Function Code 3	F00.00~F25.xx	0.01	25.00	○
F25.03	User Function Code 4	F00.00~F25.xx	0.01	25.00	○
F25.04	User Function Code 5	F00.00~F25.xx	0.01	25.00	○
F25.05	User Function Code 6	F00.00~F25.xx	0.01	25.00	○
F25.06	User Function Code 7	F00.00~F25.xx	0.01	25.00	○
F25.07	User Function Code 8	F00.00~F25.xx	0.01	25.00	○
F25.08	User Function Code 9	F00.00~F25.xx	0.01	25.00	○
F25.09	User Function Code 10	F00.00~F25.xx	0.01	25.00	○
F25.10	User Function Code 11	F00.00~F25.xx	0.01	25.00	○
F25.11	User Function Code 12	F00.00~F25.xx	0.01	25.00	○
F25.12	User Function Code 13	F00.00~F25.xx	0.01	25.00	○
F25.13	User Function Code 14	F00.00~F25.xx	0.01	25.00	○
F25.14	User Function Code 15	F00.00~F25.xx	0.01	25.00	○
F25.15	User Function Code 16	F00.00~F25.xx	0.01	25.00	○
F25.16	User Function Code 17	F00.00~F25.xx	0.01	25.00	○
F25.17	User Function Code 18	F00.00~F25.xx	0.01	25.00	○
F25.18	User Function Code 19	F00.00~F25.xx	0.01	25.00	○
F25.19	User Function Code 20	F00.00~F25.xx	0.01	25.00	○
F25.20	User Function Code 21	F00.00~F25.xx	0.01	25.00	○
F25.21	User Function Code 22	F00.00~F25.xx	0.01	25.00	○
F25.22	User Function Code 23	F00.00~F25.xx	0.01	25.00	○
F25.23	User Function Code 24	F00.00~F25.xx	0.01	25.00	○
F25.24	User Function Code 25	F00.00~F25.xx	0.01	25.00	○
F25.25	User Function Code 26	F00.00~F25.xx	0.01	25.00	○
F25.26	User Function Code 27	F00.00~F25.xx	0.01	25.00	○

## Appendix A EN650A Mini multi-function PMSM Inverter

F25.27	User Function Code 28	F00.00~F25.xx	0.01	25.00	○
F25.28	User Function Code 29	F00.00~F25.xx	0.01	25.00	○
F25.29	User Function Code 30	F00.00~F25.xx	0.01	25.00	○

F26-Fault Record Function Parameter Group					
Function code	Name	Set range	Min. Unit	Factory Default	Modification
F26.00	The last fault record	0:No fault 1:Overcurrent at acceleration 2:Overcurrent at deceleration 3:Overcurrent at constant speed 4:Overvoltage at acceleration 5:Overvoltage at deceleration 6:Overvoltage at constant speed 7:Overvoltage at motor halt 8:Undervoltage at run 9:Drive overload protection 10:Motor overload protection 11:Motor under-load protection 12:Input phase loss 13:Output phase loss 14:Inverter module protection 15:Short circuit to earth at run 16:Short circuit to earth when power on 17:Drive overheat 18:R:external device fault 19:Current detect circuit fault 20:External interference 21:Internal interference—main clock etc 22:PID provide lost 23:PID feedback lost 24:PID error value abnormal 25:Terminal protection activate 26:Communication fault 27~29:reserved 30:EEROM read-write error 31:Temperature detection disconnection 32:Auto-tuning fault 33:Contactor abnormal 34:Factory fault 1 35:Factory fault 2 36:Capacitor overheat(few mode with overheat protection) 37:Encoder disconnection 38:Over-speed protection 39~50:Reserved	1	0	*
F26.01	The last two fault records	Same as above	1	0	*
F26.02	The last three fault records	Same as above	1	0	*

## Appendix A EN650A Mini multi-function PMSM Inverter

F26.03	The last four fault records	Same as above	1	0	*
F26.04	Setup frequency at the last one fault	0.00Hz~Upper limit Fre.	0.01 Hz	0.00 Hz	*
F26.05	Output frequency at the last one fault	0.00Hz~Upper limit Fre.	0.01 Hz	0.00 Hz	*
F26.06	Output current at the last one fault	0.0~6553.5A	0.1A	0.0A	*
F26.07	DC bus voltage at the last one fault	0.0~6553.5V	0.1V	0.0V	*
F26.08	Module temperature at the last one fault	0~125°C	1°C	0°C	*
F26.09	Input terminal status at the last one fault			0	*
F26.10	Accumulated run time at the last one fault	0~65535min	1min	0min	*
F26.11	Setup frequency at the last two fault	0.00Hz~Upper limit Fre.	0.01 Hz	0.00 Hz	*
F26.12	Output frequency at the last two fault	0.00Hz~Upper limit Fre.	0.01 Hz	0.00 Hz	*
F26.13	Output current at the last two fault	0.0~6553.5A	0.1A	0.0A	*
F26.14	DC bus voltage at the last two fault	0.0~6553.5V	0.1V	0.0V	*
F26.15	Module temperature at the last two fault	0~125°C	1°C	0°C	*
F26.16	Input terminal status at the last two fault			0	*
F26.17	Accumulated run time at the last two fault	0~65535h	1h	0h	*

### F24-Reserved parameters group 6

Function code	Name	Set range	Min. Unit	Factory Default	Modification
F27.00	User password	00000~65535	1	00000	○
F27.01	Manufacturer password	00000~65535	1	00000	○

### C-Monitor Function Parameter Group

Function Code	Name		Min. Unit	Factory Default	Modification
C-00	Display the parameter of F00.01、F00.07 definition				
C-01	Display the parameter of F00.02、F00.08 definition				
C-02	Display the parameter of F00.03、F00.09 definition				

## Appendix A EN650A Mini multi-function PMSM Inverter

C-03	Display the parameter of F00.04、F00.10 definition				
C-04	Display the parameter of F00.05、F00.11 definition				
C-05	Display the parameter of F00.06、F00.12 definition				

## Appendix B Free-port Communication Protocol

### B.1 Summarization

We provide the customer with general RS485/RS232 communication interface in our EN630 series frequency inverter. For the users, through the communication interface upper device (such as PC, PLC controller etc.) can perform centralized monitor to the inverter (such as setting inverter parameter, controlling run of inverter, reading work state of the inverter) and also long-distance control keypad can be connected to realize diverse operating requirement of the user.

This communication protocol is interface criterion file designed for realizing above-mentioned function, please read it earnestly and program according to it so that realize long-distance and network control to the inverter.

### B.2 Protocol content and description

#### B.2.1 Communication net buildup mode

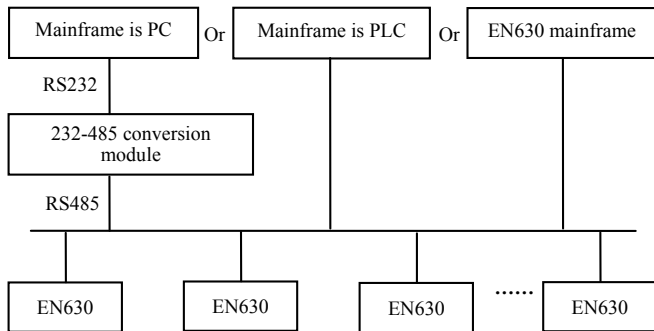

#### B.2.2 Communication mode

At present, EN630 inverter can be used as not only auxiliary device but also mainframe device in RS485, if the inverter is used as auxiliary device, master device can be completed by PC, PLC or human interface, and if used as mainframe device, the main-auxiliary control of the inverter can be complement by it, Specific communication mode is as mentioned below:

- (1) PC or PLC as mainframe, inverter as auxiliary device, point-to-point



communication between mainframe and auxiliary device.

(2) Auxiliary device don't response when mainframe send out command by broadcast address.

(3) User can set local address, baud rate and data format of the inverter through auxiliary device keypad.

(4) Auxiliary device report current failure information to mainframe in the last response frame.

(5) EN630 provides RS485 interface.

### B.2.3 Transport mode

Asynchronous serial, half-duplex transmission mode. Default format and transport rate: 8-N-1, 9600bps. For specific parameter setting please see description for F05 group function code.

(Remark: The definition for this parameter is only effective under free – port communication mode, and definition for other parameters are the same as original)

F05.00	Protocol selection	0:Modbus protocol 1:Reserved 2:Profibus protocol(Extension effective) 3:CanLink protocol(Extension effective) 4:CANopen protocol(Extension effective) 5:Freedom protocol 1(Can modify all function parameters of EN500/EN600) 6:Freedom protocol 2 (Can only modify part of function parameter of EN500/EN600) Remark: Expansion card is needed if select protocol 2, 3, 4	1	0	×
F05.01	Baud rate configuration	LED first bit: free protocol and Modbus baud rate selection 0:300BPS 1:600BPS 2:1200BPS 3:2400BPS 4:4800BPS 5:9600BPS 6:19200BPS 7:38400BPS 8:57600BPS	1	005	×
F05.02	Data format	LED first bit: Freedom protocol and Modbus protocol data format 0:1-8-1 format, no checkout, RTU 1:1-8-1 format, even checkout, RTU 2:1-8-1 format, odd checkout, RTU 3:1-7-1 format, no checkout, ASCII		00	×

## Appendix B Free-port Communication Protocol

		4:1-7-1 format, even checkout, ASCII 5:1-7-1 format, odd checkout, ASCII			
F05.03	Local address	0~247, 00 is master station address	1	1	×

### B.2.4 Data command frame format

Main device command frame format																		
Sending order	1	2	3	4	5	6	7	8	9	10	11	12	13	14	15	16	17	18
	frame head	auxiliary device address	auxiliary device address	main device command	main device command	assistant index	assistant index	command index	command index	set data	set data	set data	set data	checkout sum	checkout sum	checkout sum	checkout sum	frame end
Definition	head	address		Command area		Index area			Setting data area				checkout area			end		
Sending byte	1	2		2		4			4				4			1		

Main device command frame format																		
Sending order	1	2	3	4	5	6	7	8	9	10	11	12	13	14	15	16	17	18

frame end	end	1
checksum sum	Checksum area	4
checksum sum		
checksum sum		
checksum sum		
run data	Run data area	4
run data		
run data		
run data		
command index	Index area	4
command index		
failure index		
failure index		
auxiliary device response	response area	2
auxiliary device response		
auxiliary device address	address	2
auxiliary device address		
frame head	head	1
	Definition	Sending byte

Fig.B-2 Command/Response frame format

Remark:

(1) “Setting data area” and “run data area” may not be existent in some command/data frame format, so in protocol command list it’s marked with “nothing”.

(2) In protocol effective character set is: ~,1, 2, 3, 4, 5, 6, 7, 8, 9, A, B, C, D, E,F and hex data 0DH, ASCII lowercase a, b, c, d, e, f are invalid.

(3) Effective command frame length is 14 or 18 byte.

### B.2.5 Explanation and description for format

(1) Frame head

It’s character“~” (namely hex 7E), single byte.

(2) Auxiliary device address

Data meanings: local address of auxiliary device, double byte. ASCII format. Inverter factory default is 01.

(3) Mainframe command/auxiliary device respond

Data meanings: mainframe send out command and auxiliary device respond to the command. Double byte, ASCII format.

Response code function classification:

Species 1>: Command code=“10”, mainframe ask auxiliary device to report current preparation state and control situation.

**Table B-1 Command code meanings for response frame response area**

Response code ASCII	Meanings		
	Preparation state of auxiliary device	Control from mainframe is allowed	To set frequency is allowed
10	Haven't get ready	No meaning	
11	Get ready	Allow	Allow
12	Get ready	Allow	Allow
13	Get ready	Don't allow	Don't allow
14	Get ready	Don't allow	Don't allow
20	Frame error		

Species 2>: Command code="11"~"15", 5 kinds of function command which mainframe send to auxiliary device, For detail please see protocol command list.

**Table B-2 Response code meanings for response frame command index area**

Response code ASCII	Meanings of response code	description
00	Auxiliary device communication and control is normal; function code modification is effective; password is correct.	
20	(1) Frame checkout error; (2) "Command area" data overrun; (3) "Index area" data overrun; (4) Frame length error/non ASCII byte exist in area except frame head, frame end.	When this response code is reported, data of "command area", "index area" and "running data area" are not reported.
30	(1) Control to auxiliary device is ineffective; (2) Ineffective function code parameter modification; (3) "Setting/Running data" area data overrun. (4) Password error.	Whether report this response code relate to current set state of auxiliary device. When report data of area, "index area" and "run data area" are reported according to protocol requirement.

(4) Auxiliary index/command index/failure index

Data meanings: Include auxiliary index byte and command index byte.

For mainframe, Auxiliary index, command index are used for cooperating mainframe command in realizing specific function.

For auxiliary device, auxiliary index, command index are used for reporting failure state code, command index are reported without modification

Data type: hex, 4 byte, ASCII format.

Command index occupy 2 low byte, data range: “00”~“FF”.

Auxiliary index occupy 2 high byte, data range: “00”~“FF”.

Auxiliary device failure state occupy “auxiliary index” byte, see table B-3.

**Table B-3 Free-port1 failure type description**

Failure code (Decimal)	Description	Failure code (Decimal)	Description
1	Overcurrent during accelerating process	19	Current detecting circuit failure
2	Overcurrent during decelerating process	20	External interference failure
3	Overcurrent during constant speed process	21	Internal interference failure
4	Overvoltage during accelerating process	22	PID provision loss
5	Overvoltage during decelerating process	23	PID feedback loss
6	Overvoltage during constant speed process	24	PID error amount exception
7	Overvoltage while halting	25	Startup terminal protection
8	Under voltage during running process	26	RS485 communication failure
9	Inverter overload protection	27	Reserved
10	Motor overload protection	28	Reserved
11	Motor underload protection	29	Reserved
12	Input phase missing	30	E <sup>2</sup> PROM read and write wrongly
13	Output phase missing	31	Temperature detection breakage
14	Inverting module protection	32	Self-tuning failure
15	Short circuit to earth during running process	33	Contacto exception
16	Short circuit to earth during electrifying process	34	Interior failure 1
17	Inverter over heating		

18	External device failure		
----	-------------------------	--	--

### Free-port 2 Failure type description

Failure code (decimal)	Description	Failure code (decimal)	Description
1	Overcurrent during accelerating process	13	Inverting module protection
2	Overcurrent during decelerating process	14	External device failure
3	Overcurrent during constant speed process	15	Current detecting circuit failure
4	Overvoltage during accelerating process	16	RS485 communication failure
5	Overvoltage during decelerating process	17	Reserved
6	Overvoltage during constant speed process	18	Reserved
7	Control power supply overvoltage	19	Under voltage
8	Inverter overload	20	System interference
9	Motor overload	21	Reserved
10	Inverter over heating	22	Reserved
11	Reserved	23	E <sup>2</sup> PROM read and write wrongly
12	Reserved		

#### (5) Checkout sum

Data meanings: frame checkout, 4 byte, ASCII.

Calculation method: accumulative sum of ASCII code value of all byte from “auxiliary device address” to “run data”.

#### (6) Frame end

Hex 0D, single byte.

### B.2.6 Protocol command list

Frame 7E and frame end 0D, address, checkout sum, ASCII character format are omitted in following description.

**Table B-4 Free-port 1 protocol command table**

Name	Mainframe order Decimal	Auxiliary index Hex	Order index Hex	Run data setting range Hex	Mainframe sending example, such as PC control operation of inverter (C language cluster format, auxiliary device is set to 01)	Run data precision	Description	
Look up auxiliary motor state	10	00	00	no	~010A00000192r	1		
Read parameter of auxiliary motor	Main setting frequency	11	00	00	no	~010B00000193r	0.01 Hz	
	Auxiliary setting frequency	11	00	01	no	~010B00010194r	0.01 Hz	
	Setting frequency	11	00	02	no	~010B00020195r	0.01 Hz	
	Output frequency	11	00	03	no	~010B00030196r	0.01 Hz	
	Output current	11	00	04	no	~010B00040197r	0.1A	
	Output voltage	11	00	05	no	~010B00050198r	1V	
	DC bus-bar voltage	11	00	06	no	~010B00060199r	0.1V	
	Load motor revolving speed	11	00	07	no	~010B0007019A\	1RPM	
	Load motor linear speed	11	00	08	no	~010B0008019B\	no	
	Inverter temperature	11	00	09	no	~010B0009019C\	1℃	
	Runtime	11	00	0A	no	~010B000A019A4\	0.1 min	
	Current accumulative runtime	11	00	0B	no	~010B000B019A5\	1H	
	Current accumulative power-on time	11	00	0C	no	~010B000C019A6\	1H	
Inverter state	11	00	0D	no	~010B000D019A7\	No		
Input terminal	11	00	0E	no	~010B000E019A8\	No		

## Appendix B Free-port Communication Protocol

state								
Output terminal state	11	00	0F	no	~010B000F01A9\r	No		
Expand output terminal state	11	00	10	no	~010B00100194\r	No		
Expanding input terminal state	11	00	11	no	~010B000F0195\r	No		
Communicational virtual input terminal state	11	00	12	no	~010B000F0196\r	No		
Internal virtual input node state	11	00	13	no	~010B000F0197\r	No		
Analog input AI1	11	00	14	no	~010B000F0198\r	No		
Analog input AI2	11	00	15	no	~010B000F0199\r	No		
Expanding analog input EAI1	11	00	16	no	~010B000F019A\r	No		
Expanding analog input EAI2	11	00	17	no	~010B000F019B\r	No		
Analog AO1 output	11	00	18	no	~010B000F019C\r	No		
Analog AO2 output	11	00	19	no	~010B000F019D\r	No		
Expanding analog EAO1 output	11	00	1A	no	~010B000F01A5\r	No		
Expanding analog EAO2 output	11	00	1B	no	~010B000F01A6\r	No		
External pulse input frequency	11	00	1C	no	~010B000F01A7\r	1Hz		
Operational panel potentiometer voltage	11	00	1D	no	~010B000F01A8\r	0.01 V		
Process PID provision	11	00	1E	no	~010B000F01A9\r	0.01 V		



## Appendix B Free-port Communication Protocol

Process PID feedback	11	00	1F	no	~010B000F01AA\r	0.01 V	
Process PID error	11	00	20	no	~010B000F0195\r	0.01 V	
Process PID output	11	00	21	no	~010B000F0196\r	0.01 Hz	
Simple PLC current segments	11	00	22	no	~010B000F0197\r	No	
External multi-section speed current segments	11	00	23	no	~010B000F0198\r	No	
Provision pressure for constant pressure water	11	00	24	no	~010B000F0199\r	0.001 Mpa	
Feedback pressure for constant pressure water	11	00	25	no	~010B000F019A\r	0.001 Mpa	
Relay state for constant pressure water	11	00	26	no	~010B000F019B\r	No	
Current length	11	00	27	no	~010B000F019C\r	No	
Accumulative length	11	00	28	no	~010B000F019D\r	No	
Current internal count	11	00	29	no	~010B000F019E\r	No	
Current internal time	11	00	2A	no	~010B000F01A6\r	No	
Setting channel for run command	11	00	2B	no	~010B000F01A7\r	No	
Main frequency provision channel	11	00	2C	no	~010B000F01A8\r	No	
Auxiliary frequency provision channel	11	00	2D	no	~010B000F01A9\r	No	
Inverter rated current	11	00	2E	no	~010B000F01AA\r	0.1A	

## Appendix B Free-port Communication Protocol

	Inverter rated voltage	11	00	2F	no	~010B000F01AB\r	1V	
	Inverter rated power	11	00	30	no	~010B000F0196\r	0.1 KW	
	Reserved							
	Reserved							
	Frequency after acceleration and deceleration	11	00	33	no	~010B00330199\r	0.01 Hz	
	Motor rotor frequency	11	00	34	no	~010B0034019A\r	0.01 Hz	
	Current provision torque	11	00	35	no	~010B0035019B\r	0.1%	
	Current output torque	11	00	36	no	~010B0036019C\r	0.1%	
	Current torque current	11	00	37	no	~010B0037019D\r	0.1A	
	Current flux current	11	00	38	no	~010B0038019E\r	0.1A	
	Auxiliary device run command	12	00	00	no	~010C00000194\r	No	
	Set current run frequency provision of auxiliary device	12	00	01	0Hz~high limit freq	~010C00010FA0027C\r	0.01 Hz	Set freq. =40.00 Hz
<b>Run control and adjusting function</b>	Auxiliary device run with run frequency provision	12	00	02	0Hz~high limit freq	~010C00020FA0027D\r	0.01 Hz	Auxiliary device run Set freq. =40.00 Hz
	Auxiliary device forward run	12	00	03	no	~010C00030197\r	No	
	Auxiliary device reverse run	12	00	04	no	~010C00040198\r	No	
	Auxiliary	12	00	05	0Hz~	~010C00050FA00	0.01	Forward

	device forward run with run frequency provision				high limit freq	280\rr	Hz	run boot-str ap Set freq. =40.00 Hz
	Auxiliary device reverse run with run frequency provision	12	00	06	0Hz~ high limit freq	~010C00060FA00 281\rr	0.01 Hz	Reverse run boot-str ap Set freq. =40.00 Hz
	Auxiliary device stop	12	00	07	no	~010C0007019B\rr	No	
	Auxiliary device jog run	12	00	08	no	~010C0008019C\rr	No	
	Auxiliary device forward jog run	12	00	09	no	~010C0009019D\rr	No	
	Auxiliary device reverse jog run	12	00	0A	no	~010C000A01A5\rr	No	
	Auxiliary device stop run	12	00	0B	no	~010C000B01A6\rr	No	
	Auxiliary device failure restoration	12	00	0C	no	~010C000C01A7\rr	No	
Software version query order	Query auxiliary device software version	15	00	00	no	~010F00000197\rr	1	

Free-Port 2 protocol command table

## Appendix B Free-port Communication Protocol

Name		Mainframe order Decimal	Auxiliary Index Hex	Order index Hex	Run data setting range Hex	Mainframe sending example, such as PC control operation of inverter (C language cluster format, auxiliary device is set to 01)	Run data precision	Description
Look up auxiliary motor state		10	00	00	no	~010A00000192\r	1	
Run control and adjusting function	Auxiliary device run command	12	00	00	no	~010C00000194\r	no	
	Set current run freq. of auxiliary device	12	00	01	0Hz~ high limit freq	~010C00010FA00 27C\r	0.01Hz	
	Auxiliary device run with run frequency provision	12	00	02	0Hz~ high limit freq	~010C00020FA00 27D\r	0.01Hz	
	Auxiliary device forward run	12	00	03	no	~010C00030197\r	no	
	Auxiliary device reverse run	12	00	04	no	~010C00040198\r	no	
	Auxiliary device forward run with run frequency provision	12	00	05	0Hz~ high limit freq	~010C00050FA00 280\r	0.01Hz	
	Auxiliary device reverse run with run frequency provision	12	00	06	0Hz~ high limit freq	~010C00060FA00 281\r	0.01Hz	
	Auxiliary device stop	12	00	07	no	~010C0007019B\r	no	
	Auxiliary device jog run	12	00	08	no	~010C0008019C\r	no	

	Auxiliary device forward jog run	12	00	09	no	~010C0009019D\r	no	
	Auxiliary device reverse jog run	12	00	0A	no	~010C000A01A5\r	no	
	Auxiliary device stop run	12	00	0B	no	~010C000B01A6\r	no	
	Auxiliary device failure restoration	12	00	0C	no	~010C000C01A7\r	no	
Software version query order	Query auxiliary device software version	15	00	00	no	~010F00000197\r	1	

Table B-5 read auxiliary device function code parameter

Function definition	Read auxiliary device function code parameter: all function code parameter except user password and manufacturer password except user password and manufacturer password						
Meanings	Frame head	Address	Order	Order index	Run data	Checkout sum	Frame end
Mainframe order	7EH	ADDR	13	See remark	4	BCC	0DH
Byte quantity	1	2	2	4	0	4	1
Auxiliary device respond	7EH	ADDR	06	See remark	Function code parameter	BCC	0DH
Byte quantity	1	2	2	4	4	4	1
Remark	Command index=combination of function code group number and hex code of function code number. For instance: If want to read parameter of F0.05 function code, order index=0005; If want to read parameter of F2.11 function code, order index =020B; If want to read parameter of F2.15 function code, order index =020F; If want to read parameter of F2.13 function code, order index =020D;						

## Appendix B Free-port Communication Protocol

	Corresponding relation between decimal and hex value of function code group No.					
	Function code group No	Decimal	Hex	Function code group No	Decimal	Hex
	F00	0	00H	F0E	14	0EH
	F01	1	01H	F0F	15	0FH
	F02	2	02H	F10	16	10H
	F03	3	03H	F11	17	11H
	F04	4	04H	F12	18	12H
	F05	5	05H	F13	19	13H
	F06	6	06H	F14	20	14H
	F07	7	07H	F15	21	15H
	F08	8	08H	F16	22	16H
	F09	9	09H	F17	23	17H
	F0A	10	0AH	F18	24	18H
	F0B	11	0BH	F19	25	19H
	F0C	12	0CH	F1A	26	1AH
	F0D	13	0DH	F1B	27	1BH
Virtual data	0~FFFF (namely 0~65535)					

Please input correct “user password” before you set user function code parameter.

**Table B-6 set auxiliary device function code parameter**

Function definition	Set auxiliary device function code parameter: all function code parameter except user password and manufacturer password						
Meanings	Frame head	Address	Order	Order index	Run data	Checksum	Frame end
Mainframe order	7EH	ADDR	14	See remark	4	BCC	0DH
Byte quantity	1	2	2	4	0	4	1
Auxiliary device respond	7EH	ADDR	06	See remark	Function code parameter	BCC	0DH
Byte quantity	1	2	2	4	4	4	1

Remark	Command index=combination of function code group number and hex code of function code number. For instance: If want to read parameter of F00.05 function code, order index=0005; If want to read parameter of F02.11 function code, order index =020B; If want to read parameter of F02.15 function code, order index =020F; If want to read parameter of F02.13 function code, order index =020D;					
	Corresponding relation between decimal and hex value of function code group No.					
	Function code group No	Decimal	Hex	Function code group No	Decimal	Hex
	F00	0	00H	F0E	14	0EH
	F01	1	01H	F0F	15	0FH
	F02	2	02H	F10	16	10H
	F03	3	03H	F11	17	11H
	F04	4	04H	F12	18	12H
	F05	5	05H	F13	19	13H
	F06	6	06H	F14	20	14H
	F07	7	07H	F15	21	15H
	F08	8	08H	F16	22	16H
	F09	9	09H	F17	23	17H
	F0A	10	0AH	F18	24	18H
	F0B	11	0BH	F19	25	19H
F0C	12	0CH	F1A	26	1AH	
F0D	13	0DH	F1B	27	1BH	
Virtual data	0~FFFF(namely 0~65535)					

## Appendix C Modbus communication protocol

### C.1 Summary

We provide general RS485 communication interface in our EN630/ EN650A inverters for the user. Through this communication interface upper device (such as HMI, PC, PLC controller and etc.) can perform centralized monitor to the inverter (Such as to set inverter parameter, control run of inverter, read work state of the inverter).

This communication protocol is interface criterion file designed for realizing above-mentioned function, please read it earnestly and program according to it so that realize long-distance and network control to the inverter.

### C.2 Communication net buildup mode

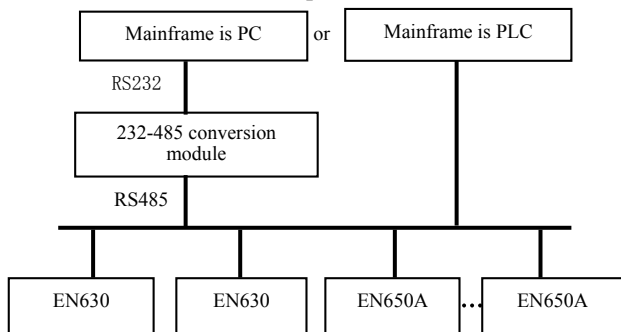

Fig.C-1 Net buildup graph

### C.3 Communication mode

At present, EN630/EN650A inverter can be used only as Slave device in RS485 net. Can realize communication between inverters through PC, PLC or HMI if it's needed. Specific communication mode is as mentioned below:

(1) PC or PLC as mainframe, inverter as Slave device, point-to-point communication between mainframe and Slave device.

(2) Slave device don't response when mainframe send out command by broadcast address.



- (3) User can set local address, baud rate and data format of the inverter through  
 (4) Slave device keypad or serial communication mode.  
 (5) EN630/ EN650A provides the RS485 interface.  
 (6) Default mode: Asynchronous serial, semiduplex transport mode. There are RTU and ASII two mode . Default format and transport rate: 8-N-1, 9600bps.

## C.4 Transmission mode

Asynchronous serial, semiduplex transport mode. Default format and transport rate: 8-N-1, 9600bps. The detail setting parameter, please refer to the F05 group function mode.

(Remark: The parameter is valid under the Modbus communication, the other parameter comply with the original service manual)

F05.00	Protocol selection	0:Modbus protocol 1:Reserved 2:Reserved 3:Reserved 4:Reserved 5:Free protocol 1(revision all the parameter of EN630/EN650A is valid) 6: Free protocol 2(only revising part parameter of EN630/EN650A is valid)	1	0	×
F05.01	Baud rate setting	LED the unit digital: free protocol and Modbus Baud rate selection 0:300BPS 1:600BPS 2:1200BPS 3:2400BPS 4:4800BPS 5:9600BPS 6:19200BPS 7:38400BPS 8:57600BPS	1	005	×
F05.02	Data format	LED the unit digital: free protocol and Modbus protocol Data format 0:1-8-1 format, no checkout, RTU 1:1-8-1 format, Odd Parity, RTU 2:1-8-1 format, Even Parity, RTU 3:1-7-1 format, no checkout, ASCII 4:1-7-1 format, Odd Parity, ASCII 5:1-7-1 format, Even Parity, ASCII		00	×
F05.03	Local address	0~247, 00 is broadcast address	1	1	×

## C.5 Data communication structure

### C.5.1 Data frame format

Using RTU mode, messages are sent at least 3.5 character time interval pause. The first transmitted field is device address, the character you can transfer is hexadecimal 0x00 ~ 0xFF. Network equipment continuously monitor the bus, including pauses. When the address field is received, all equipment determine whether it is sent to their own. When the last character of the packet transfer is complete, at least a 3.5 character times pause mean the end of the message. A new

Message can begin after this pause. The entire message frame must be transmitted as a continuous flow. If a new message start transmitting in less than 3.5 character times after a message and then receiving device will consider it a continuation of the previous message. This will cause an error, because in the final CRC field value can not be right.

RTU frame format as the table below:

Frame Header	3.5 characters time pause
Slave address	Slave address:0~247
Communication command code	03H:read slave parameter 06H:write slave parameter
Data content DATA	The contents of packet: Parameter address(16bit); Number of parameter or bytes of parameter value; Parameter value(16bit)
Data content DATA	
.....	
.....	
CRC check value low byte	16bit Unsigned check value
CRC check value high byte	
Closing Flag	3.5 characters time pause

Regarding generation method of CRC check value, please refer to Section A.9.

ASCII frame format as the table below:

Frame Header	':'(0x3A)
Slave address Hi	Slave address: Combined by 2 ASCII code
Slave address Lo	8 bit slave address 0~247
Command code Hi	Command code: 8 bit command code combined by 2 ASCII code
Command code Lo	03H:read slave parameter 06H:write slave parameter
Data content DATA	The contents of data packet:
Data content DATA	N pieces of 8bit data content combined by 2*N pieces of ASCII code
.....	

.....	
LRC CHK Hi	LRC check value includes 2 pieces of ASCII code
LRC CHK Lo	
Closing Flag Hi	Closing Flag Hi = CR(0x0D)
Closing Flag Lo	Closing Flag Lo = LF(0x0A)

### C.5.2 Host read slave parameter

Command code 03H. Host can read one or more parameter( up to ten) by initiating a communication transaction .

E.g., read 2 contiguous inverter parameter values from the address 0000H of inverter whose address is 01, the contents of host command :

ADR	01H
CMD	03H
Parameters initial address high byte	00H
Parameters initial address low byte	00H
Number of parameter high byte	00H
Number of parameter low byte	02H
CRC check value low byte	C4
CRC check value high byte	0B

The contents of slave reply:

ADR	01H
CMD	03H
Parameter value bytes	04H
Address 0000H content high byte	00H
Address 0000H content low byte	00H
Address 0001H content high byte	00H
Address 0001H content low byte	03H
CRC check value low byte	BA
CRC check value high byte	F2

### C.5.3 Host write slave parameter

Command code 06H. Host can write an parameter by initiating a communication transaction .

E.g.,The decimal system 5000 (1388H) written to the inverter 0101H address whose slave address is 02, host command including:

ADR	02H
CMD	06H
Parameter address high byte	01H

## Appendix C Modbus communication protocol

Parameter address low byte	01H
Parameter value high byte	13H
Parameter value low byte	88H
CRC check value low byte	D4
CRC check value high byte	93

The contents of slave reply:

ADR	02H
CMD	06H
Parameter address high byte	01H
Parameter address low byte	01H
Address 0101H content high byte	13H
Address 0101H content low byte	88H
CRC check value low byte	D4
CRC check value high byte	93

## C. 6 Data communication address allocation

### C.6.1 Function code F00-F26 group communication address

Inverter function parameter's MODBUS communication address addressing process follows PPnn way: PP means high byte of the address, corresponding to function parameter's group number; nn means low byte of the address, corresponding to function code parameter's group internal code. For example: F3.21 function code's communication address is 0315H, 03H is the hex form of group number 3, 15H is the hex form of group internal code 21.

F00.00~F26.17 communication address is 0000H~1A11H, F26 group fault record parameter start address is 1A00H.

### C.6.2 Control command and status word communication address

Variable Name	Communication address	Reading-writing attribute	Command data or response value meaning
Run command word	1E00H	Reading and writing	1: reserved
			2: Jog stop command
			3: forward JOG run
			4: reversal JOG run
			5: run
			6: stop
			7: forward run
			8: reversal run

			9: fault reset 10: reserved
Serial port value setting	1E01H	Reading and writing	F01.02 while hundreds place=0, 5000 represents 50.00 Hz F01.02 while hundreds place=1, 10000 represents F01.11
Inverter status	1E02H	Reading only	BIT0: bus voltage set BIT1: the ordinary run command effectively BIT2: JOG command effectively BIT3: Running BIT4: the current running direction is reverse BIT5: the operating instructions is reverse direction BIT6: deceleration braking BIT7: acceleration BIT8: deceleration BIT9: alarm BIT10: fault BIT11: current limit BIT12: fault self recovery BIT13: self tuning BIT14: Free stop State BIT15: speed tracking start
Alarm code	1E03H	Reading only	0: no alarm 1 ~ 50: the current alarm code



Note

Modbus communication address 1E01(frequency setting)can be torque setting and pressure setting address.

### C.6.3 Monitor parameter communication address

Variable name	Communication address	read-write attribute	Command data or response value
C-00	1C00H	Reading	Monitoring parameters 1
C-01	1C01H	Reading	Monitoring parameters 2
C-02	1C02H	Reading	Monitoring parameters 3
C-03	1C03H	Reading	Monitoring parameters 4
C-04	1C04H	Reading	Monitoring parameters 5
C-05	1C05H	Reading	Monitoring parameters 6

## C.6.4 Inside hidden parameters

Variable name	Communication address	read-write attribute	means of command data or response value
PID Communication presetting value	1D00H	read-write	Range:0~1000 (1000 represents 10.00V)
Torque communication presetting value	1D01H	read-write	Range:0~2000(2000 represents 200.0% rated motor torque)
Communication AO1 given value	1D02H	read-write	Range: 0~4000(4000 represents 10.00V or 20.00mA)
Communication AO2 given value	1D03H	read-write	Range: 0~4000 (4000 represents 10.00V or 20.00mA)
Communication EAO1 given value	1D04H	read-write	Range: 0~4000 (4000 represents 10.00V or 20.00mA)
Communication EAO2 given value	1D05H	read-write	Range: 0~4000 (4000 represents 10.00V or 20.00mA)
Communication DO given value	1D06H	read-write	Range: 0~4000 (4000 represents 10.00V or 20.00mA)
Communication EDO given value	1D07H	read-write	Range: 0~4000 (4000 represents 10.00V or 20.00mA)
The communication output terminal given value	1D08H	read-write	BIT0:Y1 BIT1:Y2 BIT2:Y3 BIT3: Y4 BIT4: RLY BIT5: EY1 BIT6: EY2 BIT7: EY3 BIT8: EY4 BIT9: ERLY1 BIT10: ERLY2
Communication virtual input terminal given value	1D09H	read-write	BIT0:CX1 ... BIT7: CX8
Positive torque limited frequency	1D0AH	read-write	Range: 0~60000 (60000 represents 600.00Hz)
Negative torque limited frequency	1D0BH	read-write	Range: 0 ~ 60000(60000 represents 600.00Hz)

Process PID feedback voltage	1D0CH	read-write	Range: 0 ~ 4000(4000 represents 10.00V)
Reserved	1D0DH	/	

## C.7 Communication error processing

Inverter receiving data packet detection error, it finds reading & writing parameter address or parameter value invalid, so reply to the host with communication error response packet. Communication error response packet (host command code +80H) as command code, with 1 byte error code.

Format for communication error response packet as follows:

ADR	01H
CMD	83H/86H
Communication error code	01H~06H (for details, please check below table)
Low byte of CRC checksum	Obtain by calculating
High byte of CRC checksum	Obtain by calculating

Meaning for each communication error code value as follows:

Communication error code value	Communication error type	Priority
0x01	CRC checksum error	1
0x02	Command code illegal	2
0x03	Register address visited illegal	3
0x04	Value to register illegal	4
0x05	Not allow to modify parameters	5
0x06	Register number read illegal	6

## C.8 Data frames examples

### C.8.1 RTU Mode

#### 1. Start 1# inverter running

Data Field	Slave Address	Order code	Register address High byte	Register address Low byte	Data High byte	Low High byte	CRC high bit	CRC Low bit
Host command frames	01	06	1E	00	00	05	4F	E1
Slave respond frames	01	06	1E	00	00	05	4F	E1

**2. Stop 1# inverter running**

Data Field	Slave Inverter Address	Order code	Register address High byte	Register address Low byte	Data High byte	Low High byte	CRC high bit	CRC Low bit
Host command frames	01	06	1E	00	00	06	0F	E0
Slave respond frames	01	06	1E	00	00	06	0F	E0

**3. Set 1# inverter given value to 50Hz**

Data Field	Slave Inverter Address	Order code	Register address High byte	Register address Low byte	Data High byte	Low High byte	CRC high bit	CRC Low bit
Host command frames	01	06	1E	01	13	88	D3	74
Slave respond frames	01	06	1E	01	13	88	D3	74

**4. Read 1# inverter running state**

Data Field	Slave Inverter Address	Order code	Register address High byte	Register address Low byte	Data High byte	Low High byte	CRC high bit	CRC Low bit
Host command frames	01	03	1E	02	00	01	23	E2
Slave respond frames	01	03	(Respond value byte quantity) 02		00	01	79	84

**C.8.2 ACSII Mode****Host read Slave, command code: 03**



## The host frame

The host frame format											
	Ending symbol	checksum	Checksum	Register number	Register number	Register number	Register number	Register address	Register address	Register address	Register address
Send byte	1	2	2	4				4			

Remark:

➤ **Begin symbol:**

The lower computer judge the frame header of ASCII based on this. It is: ‘:’

➤ **Slave address:**

Single inverter ID code, range:0~247.

Thereinto, 0 is broadcast address. Broadcast address can control all the lined Slave simultaneously, and the Slave will not send back any Data to the host. That means the Slave only accept and do not send.

Modbus protocol without host address.

➤ **Command code:**

Reading the command of parameter or data from inverter , the value is: ‘0’3’.

➤ **Register address:**

The internal memory address of inverter function parameter is of 4 byte, which is ASCII mode transformed from Hexadecimal. Corresponding relation between specific parameters and memory address can be seen in the later table.

➤ **Register number:**

The number of parameters read by a frame, it is 4 byte. It is ASCII mode transformed from Hexadecimal.

➤ **Checksum:**

From “slave address” to the character before checksum, the LRC checksum of the character string. Function terminal can be seen on the end of the text.

➤ **Ending code:**

Enter, line break. is:0x0D,0x0A

## Response frame

Response frame format										
Ending code	checksum	checksum	Data string value	Data byte	Data byte	Command code	Command code	Slave address	Slave address	Frame begin symbol

Send byte	1	2	2	2	N*2	2	2
-----------	---	---	---	---	-----	---	---

Remark:

➤ **Begin code:**

The lower computer judge the frame of ASCII frame. This is ':'.

➤ **Slave address:**

Single inverter ID code, range:0~247.

Thereinto, address 0 is broadcast address. Broadcast address can control all the lined Slave simultaneously, and the Slave will not send back any Data to the host. That means the Slave only accept and do not send.

Modbus protocol is without host address.

➤ **Command code:**

The command of reading parameter or data from inverter, the value is:'0'3'.

➤ **Data byte:**

The number of parameters read by a frame. It is 4 byte, which is ASCII mode transformed from hexadecimal.

➤ **Data string value:**

The detail return Data, the length of Data string is the register address "Data byte", which is ASCII mode transformed from hexadecimal. Range: 4~40 byte

➤ **Checksum:**

From "slave address" to the character before checksum, the LRC checksum of the character string. The function terminal can be seen in the later text.

**Ending symbol:** enter, line break. Is 0x0D,0x0A

The followings are the example of command frame and return frame, all the Data are ASCII character.

➤ **Inquiry frame:**

: 0 1 0 3 0 0 0 1 0 0 0 1 F A \n\r

(The detail introduction of every byte)

“:”: beginning symbol

0 1: Slave address

0 3: Read the command

0 0 0 1: Storage address of reading parameter

0 0 0 1: The number of reading the parameter

F A: {0 1 0 3 0 0 0 1 0 0 0 1} for LRC checksum.

0xFA = 0x100 - (0x01 + 0x03 + 0x00 + 0x01 + 0x00 + 0x01)

➤ **Response frame:**

: 0 1 0 3 0 2 0 0 3 3 C 7 \n\r

(The detail introduction of every byte)

“:”: beginning symbol

0 1: Slave address

**0 3**:read the command

**02**:The byte length of return parameter Data.

**0 0 33**:return parameter, current storage value

**C 7**:{ **0 1 0 3 0 2 0 0 3 3** } for LRC checksum.

**0xC7 = 0x100 - (0x01 + 0x03 + 0x02 + 0x00 + 0x033)**

The main frame writes slave address single register, command code: **06**

#### The host frame

The host frame format																
	Frame begin symbol	Slave address	Slave address	Slave address	Command code	Register address	Register address	Register address	Register address	Data	Data	Data	Data	Checksum	checksum	Ending symbol
Send byte	1	2	2	2		4				4				2		2

Remark:

➤ **Slave address:**

Single inverter ID code, range:0~247.Thereinto, address 00 is broadcast address.

➤ **Command code:**

Read parameter from inverter or command of Data, the value is:06

➤ **Register address:**

The storage address of inverter function parameter, is double byte. The high byte is in the front and the low byte is in the back.

The detail relation between parameter and storage address can be seen in the later excel.

➤ **Data:**

The new value of revised parameter.

➤ **Checksum:**

From “slave address” to the character before checksum, the LRC checksum of the character string.

#### Response frame

Response frame format																
	Frame begin symbol	Slave address	Slave address	Command code	Command code	Register address	Register address	Register address	Register address	Data	Data	Data	Data	Checksum	Checksum	Ending symbol

Send byte	1	2	21	4	4	2	2
-----------	---	---	----	---	---	---	---

Remark:

➤ **Slave address:**

Single inverter ID code, range:0~247. Thereinto, address 00 is broadcast address.

➤ **Command code:**

Read parameter from inverter or command of Data, the value is:06

➤ **Register address:**

The storage address of inverter function parameter, is double byte. The high byte is in the front and the low byte is in the back.

The detail relation between parameter and storage address can be seen in the later excel.

➤ **Data:**

The new value of revised parameter.

➤ **Checksum:**

From “slave address” to the character before checksum, the LRC checksum of the character string.

The followings are the example of command frame and return frame, all the Data are ASCII character.

➤ **Inquiry frame:**

:0106010113885C\n\r

(The detail introduction of every byte)

“:”: beginning symbol

01: Slave address

06: write command

0101: storage address of writing parameter

1388: the value of writing parameter

5C: { 010601011388 } for LRC checksum.

0x5C = 0x100 - (0x01 + 0x06 + 0x01 + 0x01 + 0x13 + 0x88)

➤ **Response frame:**

:0106010113885C\n\r

(Detail introduction of every byte)

“:”: beginning symbol

01: Slave address

06: write command

0101: storage address of writing parameter

1388: the value of writing parameter

5C: { 010601011388 } for LRC checksum.

0x5C = 0x100 - (0x01 + 0x06 + 0x01 + 0x01 + 0x13 + 0x88)



Note

- (1) ASCII frame realizes transform by that 8Bit hexadecimal is divided as different 2 character of 4, and then grouped as hexadecimal of one 8Bit when reaching the destination.
- (2) Frame header, add“:”, frame footer adds“0xda” the enter line break character.
- (3) The valid character in the protocol is: 0, 1, 2, 3, 4, 5, 6, 7, 8, 9, A, B, C,D,E,F and hexadecimal 0DH, lower case ASCII letter a,b,c,d,e,f is invalid.
- (4) The subject data volume is the 2 times as RTU, checksum adopt LRC check.
- (5) For the other information, please refer to the official standard protocol when need.

## C.9 CRC checkout mode

CRC checkout value calculating function written by C language is as follows:

```

unsigned int cal_crc_value (unsigned char *pval, unsigned char len)
{
    unsigned int crc_value=0xFFFF;
    unsigned int i;

    while(len--)
    {
        crc_value ^= *pval++;
        for(i=0; i<8; i++)
        {
            if(crc_value & 0x0001)
            {
                crc_value >>= 1;
                crc_value ^= 0xA001;
            }
            else
            {
                crc_value >>= 1;
            }
        }
    }
    return(crc_value);
}

```

## Appendix D Braking unit and braking resistance

### D.1 Braking unit and braking resistance

The motor's electric potential energy will charge inverter's capacitance up reversely if speed of the motor descends too quickly or load of the motor wobbles too quickly while the inverter is running, which will increase the voltage upon power modules suddenly and is easy to make the inverter damaged. The inverter will control it according to load size and performance. You only need to connect external braking resistance to realize timely energy discharge when the braking function is needed. To connect external resistance is a kind of energy consumption braking mode, as all the energy is consumed by the braking resistance.

EN630/EN650A-2S0004~EN630/EN650A-2S0015, EN630/EN650A-4T0007, EN630/EN650A-4T0015 have been configured built-in braking unit.

When braking function needed, please connect external braking resistance according to below table.

**Configuration table of braking unit and braking resistor configuration as well as circumscribed braking resistor**

Inverter type	Inbuilt braking unit	Inbuilt braking resistor	External braking resistor	Quantity	Power of braking resistor (50% braking rate)	Power of braking resistor (10% braking rate)
EN630/EN650A-2S0004	Inbuilt	No	$\geq 400\Omega$	1PCS	$\geq 500W$	$\geq 100W$
EN630/EN650A-2S0007	Inbuilt	No	$\geq 400\Omega$	1PCS	$\geq 500W$	$\geq 100W$
EN630/EN650A-2S0015	Inbuilt	No	$\geq 400\Omega$	1PCS	$\geq 500W$	$\geq 100W$
EN630/EN650A-4T0007	Inbuilt	No	$\geq 500\Omega$	1PCS	$\geq 600W$	$\geq 120W$
EN630/EN650A-4T0015	Inbuilt	No	$\geq 500\Omega$	1PCS	$\geq 600W$	$\geq 120W$



***ENC*** ShenZhen Encom Electric Technologies CO.,LTD.

**Address: Floor 6, Building 2 West, Pingshan Minqi Science & Technology Park, Taoyuan Str., Nanshan District, Shenzhen, China**

**Website: <http://www.encvfd.com>**

**Email: [encvfd@encvfd.com](mailto:encvfd@encvfd.com)    [encvfd@enc.net.cn](mailto:encvfd@enc.net.cn)**

**Tel: +86-755-26984485    Fax: +86-755-26985120**