



ISO9001 Quality Management System Authentication



EDS780 Series

220V AC 0.75KW

Series Inverter

Ver. : 1.2

Users' Manual

SHENZHEN ENCOM ELECTRIC TECHNOLOGIES CO., LTD.

CONTENT

1	Safety information and use notice points.....	1
1.1	Safety precautions.....	1
1.2	Use range	2
1.3	Use notice points.....	2
1.4	Scrap notice points.....	4
2	Type and specification of the inverter	5
2.1	Incoming inverter inspect	5
2.2	Type explanation.....	5
2.3	Series type explanation.....	5
2.4	Outer size and gross weight.....	6
2.5	Basic running wiring diagram	6
2.6	The inverter interface specifications	7
2.7	Operation and use of key board.....	8
3	Function parameter schedule graph	9
3.1	Symbol description	9
3.2	Function parameter schedule graph.....	9
4	Troubleshooting.....	21
4.1	Failure and countermeasure.....	21
4.2	Failure record lookup.....	24
5	Maintenance.....	25
5.1	Routine maintenance	25
5.2	Inspection and replacement of damageable parts.....	25
5.3	Repair guarantee	26
5.4	Storage	26

1 Safety information and use notice points

In order to ensure the safety of your personal and equipment, before using the inverter, please read this chapter of contents conscientiously.

1.1 Safety precautions

There are four kinds of safe relevant warnings in this service manual, they are as follows:



warning

This symbol explains items that need to be paid attention to when being operated.



note

This symbol is briefed on some useful information.



danger

This symbol briefs on: If does not operate on request, may make the body injured or the equipment damaged.



danger

This symbol briefs on: If does not operate on request, may cause death, severely injured or serious property loss.

- (1) Forbid to connect U, V, W output end to AC power supply, otherwise cause the complete damage of the inverter.
- (2) The inverter is forbidden to install on the flammables, otherwise have danger of fire.
- (3) Don't install it in the environment with explosive gas, otherwise have danger of causing explosion.
- (4) After connecting main loop, should carry on insulating treatment to bare wiring end, otherwise have danger of getting an electric shock.
- (5) If being connected to the power supply, don't operate the inverter with moist hands, otherwise have danger of getting an electric shock.
- (6) The ground terminal of the inverter must be grounded well.
- (7) Inverter being connected to power supply, please don't open cover and carry on wiring, can connect the wire or check only after closing power for 10 minutes.
- (8) Only qualified personnel may carry on wiring and forbid leaving over any conductive thing in machine, otherwise have danger of getting an electric shock or causing damage of the inverter.
- (9) Inverter stored for over half a year, should be stepped up gradually with voltage regulator first while having the electricity, otherwise have danger of getting electric shock and explosion.



danger



- (1) It is prohibited that connect AC220V signal to control ends except TA, TB, TC, otherwise have danger of damaging property.
- (2) If the inverter is damaged or without all parts, please don't install and operate it, otherwise have danger of fire or cause personnel to be injured.
- (3) When installing, should choose a place where can endure the inverter, otherwise have danger of injuring personnel or damaging property while falling down.

1.2 Use range

- (1) This inverter is only suitable for three phases AC asynchronous motor in general industrial field.
- (2) While applying inverter to such equipments that relate much to the life, great property, safety devices etc., must handle cautiously, and consult with producer, please.
- (3) This inverter belongs to the control device of general industrial motor, if used in dangerous equipment, must consider the security safeguard procedures when the inverter breaks down.

1.3 Use notice points

- (1) EDS780 series inverter is voltage-type inverter, so temperature, noise and vibration slightly increasing compared to power source running when using, belongs to normal phenomenon.
- (2) If need to run for a long time with constant torque of low-speed, must select motor of frequency conversion for use. Use general asynchronous AC motor when running at a low speed, should control temperature of the motor or carry on heat dissipation measure forcedly, so as not to burn the generator.
- (3) Such mechanical device needing lubricating as the gearbox and gear wheel, etc., after running at a low speed for a long time, may be damaged as lubrication result become poor, please take necessary measure in advance.
- (4) When the motor running with frequency above specified, besides considering the vibration, noise increase of the motor, must also confirm speed range of the motor bearing and the mechanical device.

- (5) For hoist and great inertia load, etc., the inverter would shut off frequently due to over-current or over-voltage failure, in order to guarantee normal work, should consider choosing proper brake package.
- (6) Should switch on/off the inverter through terminal or other normal order channels. It is prohibited that switch on/off the inverter frequently by using strong electric switch such as magnetic control conductor, otherwise will cause the equipment to be damaged.
- (7) If need to install such switch as the magnetic control conductor, etc. between inverter output and the motor, please guarantee the inverter is switched on/off without output, otherwise may damage the inverter.
- (8) The inverter may meet with mechanical resonance of the load within certain range of frequency output, can set up jumping frequency to evade.
- (9) Before using, should confirm the voltage of the power is within the working voltage range allowed, otherwise should vary voltage or order special inverter.
- (10) In the condition of altitude above 1000 meters, should use the inverter in lower volume, reduce output current by 10% of specified current after each 1500 meters height increasing.
- (11) Should make insulation check to the motor before using it for the first time or after a long time placement. Please inspect with 500V voltage-type megohm meter according to method shown as graph and insulation resistance should not be smaller than $5\text{ M}\Omega$, otherwise inverter may be damaged.
- (12) To forbid assembling capacitor for improving power factor or lightningproof voltage-sensible resistance etc., otherwise will cause malfunction trip of the inverter or damage of the parts, shown as graph 1-1.
- (13) Remind: EDS780 inverter require long-term work at full capacity, the customer must have an external cooling fan, or it may overheat protection fault and affect the frequency normal life! (Inverter output current below 4A, noneed to use an external fan.)

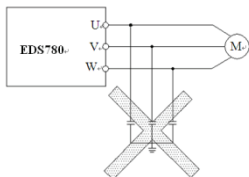

Fig.1-1 frequency converter prohibit use of capacitor

1.4 Scrap notice points

When disposing scrap inverter and its parts, please note:

- (1) The unit: please discard as industrial useless.
- (2) Electrolytic capacitor: when burning the inverter electrolytic capacitor in it may explode.
- (3) Plastic: when plastic, rubber parts etc. in the inverter are burning, they may bring bad, poisonous gas, so please be ready to safeguards.

2 Type and specification of the inverter

2.1 Incoming inverter inspect

- (1) Check if there is damage during transportation and inverter itself has damage or fall-off parts.
- (2) Check if parts presented in packing list are all ready.
- (3) Please confirm rated data of the inverter is in line with your order requirement.

Our product is guaranteed by strict quality system during manufacturing, packing, transportation etc., please contact our company or local agent rapidly if some careless omission or mistake arise, we'll deal with it as soon as possible.

2.2 Type explanation

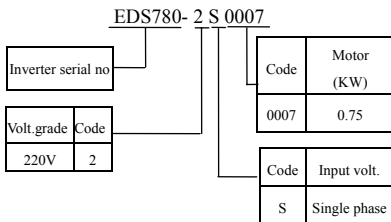

Fig. 2-1 type description

2.3 Series type explanation

Table 2-1 series type explanation

Inverter type	Rated power (KVA)	Rated output current (A)	Adapted motor (KW)
EDS780-2S0007	1.8	4.7	0.75

2.4 Outer size and gross weight

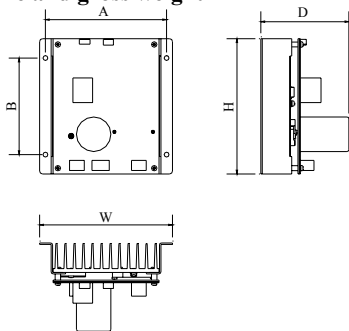

Fig.2-2 Outline Image

Table 2-2 EDS780-2S0007 mounting size

Inverter type	W (mm)	H (mm)	D (mm)	A (mm)	B (mm)	Fixing aperture (mm)
EDS780-2S0007	147.4	140.0	92.0	135.2	100	5

2.5 Basic running wiring diagram

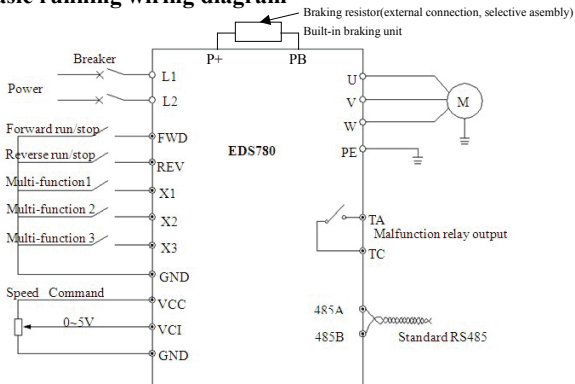

Fig.2-3 Basic running wiring diagram

2.6 The inverter interface specifications

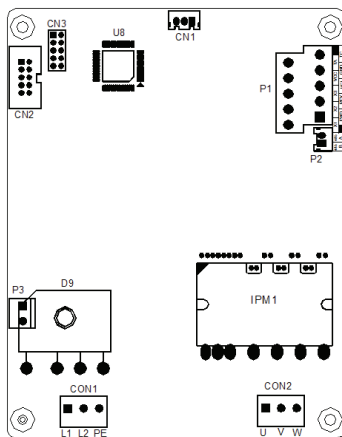

Fig.2-4

(1) P1 terminal function description

item	symbol	name	Function description	Spec.
run command	FWD	Forward run command	Forward reverse run command, see F5.08 group double-wire and three-wire control function description	Input impedance: $R=2K\ \Omega$ Max. input frequency: 200Hz
	REV	Reverse run command		
Multi-function input termina	X1	Multi-function input 1	Used for multi-function input terminal, for detailed see function parameter F5 group input end function description.	Max. output current: 50mA
	X2	Multi-function input 2		
	X3	Multi-function input 3		
	VCC	+5V power supply	Provide +5V power supply. (negative pole: GND)	
	GND	+5V power supply negative pole	Reference ground of analog signal and +5V power supply	
Analog value input	VCI	Analog value input VCI	Accept analog voltage input	Input voltage range: 0~5V (Input impedance: $10K\ \Omega$) Resolution: 1/1000

(2) P2 terminal function description

item	symbol	name	Function description	spec
communication	485A	485 communication interface	485 difference signal positive end	For standard 485 communication interface please use twisted-pair or STP
	485B		485 difference signal negative end	

(3) P3 terminal function description:

Terminal label	Terminal function description
P+	External braking resistor: the resistance range of the braking resistor should not be lower than 200 Ω .
PB	

2.7 Operation and use of key board

Keypad is main unit for receiving command, displaying parameter. Outer dimension of EN-KB5 is as Fig.2-5:

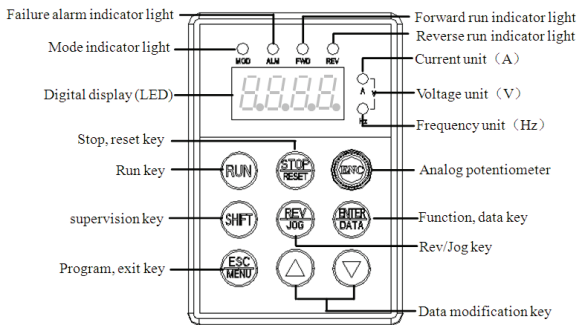

Fig.2-5 keypad layout sketch(EN-KB5)

3 Function parameter schedule graph

3.1 Symbol description

- × ---- parameter can't be changed in process of running
 ○ ---- parameter can be changed in process of running
 * ---- read-only parameter, unmodifiable

3.2 Function parameter schedule graph

F0 –basic run function parameter group					
function code	name	Set range	unit	Factory default	Modification
F0.00	Frequency input channel selection	0: keypad analog potentiometer setting 1: keypad digital setting 2: terminal UP/DOWN adjust setting (stored after power off) 3: serial port setting 4: VCI analog setting (VCI-GND) 6: reserved 7: reserved 8: combination setting 9: terminal UP/DOWN adjust setting (not stored after power off) 10: provision serial port (stored after power off)	1	1	○
F0.01	Freq. digit setting	Lower limit Freq. ~ upper limit Freq.	0.01Hz	50.00Hz	○
F0.02	Run command channel selection	0: keypad run control 1: terminal run command control (keypad stop command ineffective) 2: terminal run command control (keypad stop command effective) 3: serial port run command control (keypad stop command ineffective) 4: serial port run command control (keypad stop command effective)	1	0	○
F0.03	Run direction setting	1 st bit: 0, forward run; 1, reserved 2 nd bit: 0, forward run allowed 1, reverse run banned 3 rd bit: REV/JOG key selection 0: as reverse run key 1: as jog key	1	100	○
F0.04	Acce/Dece mode selection	0: linear accelerating decelerating mode 1: S curve accelerating decelerating mode	1	0	×
F0.05	S curve start section time	10.0 (%) — 50.0 (%) (Acce/Dece time) F0.05+F0.06 ≤ 90 (%)	0.1(%)	20.0(%)	○

F0.06	S curve rise time	10.0 (%) - 70.0 (%) (Acce/Dece time) F0.05+F0.06≤90 (%)	0.1(%)	60.0(%)	○
F0.07	accelerating decelerating time unit	0: second 1: minute	1	0	×
F0.08	Acce time 1	0.1 - 6000.0	0.1	20.0	○
F0.09	Dece time 1	0.1 - 6000.0	0.1	20.0	○
F0.10	Upper limit freq.	Lower limit freq. - 400.00Hz	0.01Hz	50.00Hz	×
F0.11	Lower limit freq.	0.00 - Upper limit freq.	0.01Hz	0.00Hz	×
F0.12	Lower limit freq. run mode	0: run at lower limit freq. 1: stop running	1	0	×
F0.13	Torque boost mode	0: manual boost 1: automatic boost	1	0	○
F0.14	Torque boost	0.0 - 20.0 (%)	0.1(%)	4.0(%)	○
F0.15	V/F curve setting	0: constant torque curve 1: degressive torque curve 1 (the 2.0nd power) 2: degressive torque curve 2 (the 1.7th power) 3: degressive torque curve 3 (the 1.2th power)	1	0	×
F0.16	reserved		1	0	×

F1 -start-up, stop, brake function parameter group

Function code	name	Set range	unit	Factory default	Modification
F1.00	Start-up run mode	0: start at start-up freq. 1: first brake, then start at start-up freq. 2: reserved	1	0	×
F1.01	Start-up freq.	0.0 - 10.00Hz	0.01Hz	0.00Hz	○
F1.02	Start-up freq. duration	0.0 - 20.0S	0.1s	0.0s	○
F1.03	Zero freq. DC braking volt.	0 - 15 (%)	1	0	○
F1.04	Zero freq. DC braking time	0.0 - 20.0S	0.1s	0.0s	○
F1.05	Stop mode	0: Dec stop 1: free stop 2: Dec + DC brake stop	1	0	×
F1.06	DC brake initiative freq. when stop running	0.0 - 15.00Hz	0.01Hz	0.00Hz	○
F1.07	DC brake time when stop running	0.0 - 20.0s	0.1s	0.0s	○
F1.08	DC brake voltage when stop running	0 - 15 (%)	1	0	○

F2 -auxiliary run function parameter group

Function	name	Set range	unit	Factory	modif-
----------	------	-----------	------	---------	--------

code				default	ication
F2.00	Analog filter time constant	0.00—30.00s	0.01s	0.20s	○
F2.01	Forward reverse run dead-section time	0.0—3600.0s	0.1s	0.1s	○
F2.02	Automatic energy save run	0: no action 1: action	1	0	×
F2.03	AVR function	0: no action 1: action all the time 2: no action only during Dec	1	0	×
F2.04	Slip frequency compensation	0~150(%)0-no slip frequency compensation	1	0	×
F2.05	Carrier wave freq.	1—10.0K	0.1K	depend on machine type	×
F2.06	Jog run frequency	0.10—50.00Hz	0.01Hz	5.00Hz	○
F2.07	Jog Acce time	0.1—60.0s	0.1s	20.0s	○
F2.08	Jog Dece time	0.1—60.0s	0.1s	20.0s	○
F2.09	reserved		1	0	×
F2.10	Principal subordinate Machine communication frequency provision proportion	0 (%)—500 (%)	1(%)	100(%)	○
F2.11	LED display control 1	0000-1111 first bit: running time 0: not display 1: display second bit: accumulative time 0: not display 1: display third bit: input terminal status 0: not display 1: display kilobit(fourth bit): output terminal status 0: not display 1: display	1	1111	○
F2.12	Reserved				
F2.13	Parameter operation control	LED 1st bit: 0: all parameter allowed to be modified 1: except this parameter, all other parameter not allowed to be modified 2: except F0.01 and this parameter, all other parameter not allowed to be modified LED 2nd bit: 0: no action 1: restore default value 2: clear history failure record LED 3rd bit: 0: lock all buttons 1: lock all buttons but not STOP key	1	0	×

		2: lock all buttons but not  STOP key 3: lock all buttons but not RUN, STOP key 4: lock all buttons but not SHIFT, STOP key			
F2.14	Communication configuration	LED first bit: baud rate selection 0: 1200BPS 1: 2400BPS 2: 4800BPS 3: 9600BPS 4: 19200BPS 5: 38400BPS LED second bit: data format 0: 1-8-1 format, no checkout 1: 1-8-1 format, even checkout 2: 1-8-1 format, odd checkout	1	03	×
F2.15	Local address	0-127, 127 is broadcast address. The inverter only receive but not send when it is set to be 127, 0 is address for main device.	1	1	×
F2.16	Communication overtime	0.0-1000.0s	0.1s	0.0s	×
F2.17	Local responson delay	0-1000ms	1ms	5ms	×
F2.18	Acce time 2	0.1-6000.0	0.1	20.0	○
F2.19	Dece time 2	0.1-6000.0	0.1	20.0	○
F2.20	Acce time 3	0.1-6000.0	0.1	20.0	○
F2.21	Dece time 3	0.1-6000.0	0.1	20.0	○
F2.22	Acce time 4	0.1-6000.0	0.1	20.0	○
F2.23	Dece time 4	0.1-6000.0	0.1	20.0	○
F2.24	Acce time 5	0.1-6000.0	0.1	20.0	○
F2.25	Dece time 5	0.1-6000.0	0.1	20.0	○
F2.26	Acce time 6	0.1-6000.0	0.1	20.0	○
F2.27	Dece time 6	0.1-6000.0	0.1	20.0	○
F2.28	Acce time 7	0.1-6000.0	0.1	20.0	○
F2.29	Dece time 7	0.1-6000.0	0.1	20.0	○
F2.30	Multisection freq. 1	Lower limit freq.—upper limit freq.	0.01Hz	5.00Hz	○
F2.31	Multisection freq. 2	Lower limit freq.—upper limit freq.	0.01Hz	10.00Hz	○
F2.32	Multisection freq. 3	Lower limit freq.—upper limit freq.	0.01Hz	20.00Hz	○
F2.33	Multisection freq. 4	Lower limit freq.—upper limit freq.	0.01Hz	30.00Hz	○
F2.34	Multisection freq. 5	Lower limit freq.—upper limit freq.	0.01Hz	40.00Hz	○
F2.35	Multisection freq. 6	Lower limit freq.—upper limit freq.	0.01Hz	45.00Hz	○
F2.36	Multisection freq. 7	Lower limit freq.—upper limit freq.	0.01Hz	50.00Hz	○
F2.37	Multisection freq. 8	Lower limit freq.—upper limit freq.	0.01Hz	5.00Hz	○
F2.38 ~ F2.44	Reserverd				
F2.45	Jumping freq. 1	0.00-400.00Hz	0.01Hz	0.00Hz	×
F2.46	Jumping freq. 1 range	0.00-30.00Hz	0.01Hz	0.00Hz	×

F2.47	Jumping freq. 2	0.00—400.00Hz	0.01Hz	0.00Hz	×
F2.48	Jumping freq. 2 range	0.00—30.00Hz	0.01Hz	0.00Hz	×
F2.49	Jumping freq. 3	0.00—400.00Hz	0.01Hz	0.00Hz	×
F2.50	Jumping freq. 3 range	0.00—30.00Hz	0.01Hz	0.00Hz	×
F2.51	Setting run time	0—65535 hours	1	0	○
F2.52	Accumulative run time	0—65535 hours	1	0	*
F2.53	RS485communication frame format selection	0: a ASCII frame of 14 byte or 18 byte 1: a hex frame of 8 byte or 10 byte, original response not changed 2: a hex frame of 8 byte or 10 byte, 12 command has no response 3: a hex frame of 8 byte or 10 byte, 14 command has no response 4: a hex frame of 8 byte or 10 byte, both 12 and 14 command have no response	1	0	×

F3 group –closed-loop run function parameter group

Function code	name	Set range	unit	Factory default	modification
F3.00	Closed-loop run control selection	0: closed-loop control ineffective 1: PID closed-loop control effective 2: reserved	1	0	×
F3.01	Provision channel selection	0: digital provision 1: VCI analog 0—5V voltage provision 2: reserved 3: keypad analog potentiometer provision	1	1	○
F3.02	Feedback channel selection	0: VCI analog input voltage 0—5V 1: reserved	1	1	○
F3.03	Specified value digital setting	0.00—10.00V	0.01	0.00	○
F3.04	Minimum specified value	0.0—maximum specified value; percentage relative to 10.00V	0.1(%)	0.0(%)	○
F3.05	feedback value responding to minimum specified value	0.0(%)—100.0(%)	0.1(%)	0.0(%)	○
F3.06	maximum specified value	Minimum specified value—100.0(%)	0.1(%)	100.0(%)	○
F3.07	feedback value responding to maximum specified value	0.0(%)—100.0(%)	0.1(%)	100.0(%)	○
F3.08	proportion gain Kp	0.000—9.999	0.001	0.050	○
F3.09	Integral gain Ki	0.000—9.999	0.001	0.050	○
F3.10	Differential gain Kd	0.000—9.999	0.001	0.050	○
F3.11	Sampling cycle T	0.01—1.00s	0.01s	0.10s	○

F3.12	Deviation margin	0.0—20.0 (%) percentage relative to 10.00V	0.1(%)	2.0(%)	○
F3.13	Integral separation PID adjusting threshold	0.0—100.0%	0.1(%)	100.0(%)	○
F3.14	Closed-top preset frequency	0—upper limit frequency	0.01Hz	0.00Hz	○
F3.15	Closed-loop preset frequency holding time	0.0-6000s	0.1s	0.0s	○
F3.16 ~ F3.26	Reserved				
F3.27	Closed-loop adjusting characteristic	0: Forward function 1: Reverse function	1	0	○
F3.28	LED initial supervision parameter selection	0: set frequency 1: output frequency 2: output current 3: output voltage 4: DC bus bar voltage 5: motor speed 6: heat sink temperature 7: run time 8: accumulative run time 9: input terminal status 10: output terminal status 11: analog input VCI/PID provision	1	1	○
F3.29	Zero freq. braking freq. at starting	0.00Hz-15.00Hz	0.01Hz	0.00 Hz	○
F3.30	Failure relay TA, TC function selection	0: inverter running (RUN) 1: frequency arriving signal (FAR) 2: frequency level detect signal (FDT1) 3: reserved 4: overload warning alarm signal (OL) 5: output frequency reach high limit (FHL) 6: output frequency reach low limit (FLL) 7: inverter under voltage blockage stop (LU) 8: external failure stop-running (EXT) 9: inverter zero speed running 10: PLC running 11: simple PLC section running finished 12: PLC finish a cycle running 13: reserved 14: inverter ready to run (RDY) 15: inverter failure 16: traverse high and low limit restriction 17: interior counter reach final value 18: interior counter reach specified value 19: set run time arriving 20: interior timing arriving 21~24: reserved		15	○
F3.31	VCI analog input gain	0-800%		100	○

F4 –simple PLC function parameter group					
Function code	name	Set range	unit	Factory default	modification
F4.00	Simple PLC running setting	LED first bit: 0: no action 1: stop after single circulation 2: keep final value after single circulation 3: consecutive circulation LED second bit: 0: start again from first section 1: continue to run at mid-section frequency LED third bit: PLC run time unit 0: second 1: minute	1	000	×
F4.01	Section 1 setting	000—621 LED first bit: frequency setting 0: multi-section freq. i (i=1~7) 1: freq. determined by F0.00 function code LED second bit: run direction selection 0: forward run 1: reverse run 2: determined by run command LED third bit: Acc/Dec time selection 0: Acce/Dece time 1 1: Acce/Dece time 2 2: Acce/Dece time 3 3: Acce/Dece time 4 4: Acce/Dece time 5 5: Acce/Dece time 6 6: Acce/Dece time 7	1	000	○
F4.02	Section 1 run time	0—6000.0	0.1	10.0	○
F4.03	Section 2 setting	000—621	1	000	○
F4.04	Section 2 run time	0—6000.0	0.1	10.0	○
F4.05	Section 3 setting	000—621	1	000	○
F4.06	Section 3 run time	0—6000.0	0.1	10.0	○
F4.07	Section 4 setting	000—621	1	000	○
F4.08	Section 4 run time	0—6000.0	0.1	10.0	○
F4.09	Section 5 setting	000—621	1	000	○
F4.10	Section 5 run time	0—6000.0	0.1	10.0	○
F4.11	Section 6 setting	000—621	1	000	○
F4.12	Section 6 run time	0—6000.0	0.1	10.0	○
F4.13	Section 7 setting	000—621	1	000	○
F4.14	Section 7 run time	0—6000.0	0.1	10.0	○

F5 –terminal correlative function parameter group					
Function code	name	Set range	unit	Factory default	modification
F5.00	Input terminal X1 function selection	0: leave control terminal unused 1: multi-section speed control terminal 2: multi-section speed control terminal 3: multi-section speed control terminal 4: multi-section speed control terminal 5: external forward run jog control 6: external reverse run jog control 7: Acce/Dece time option terminal 1 8: Acce/Dece time option terminal 2 9: Acce/Dece time option terminal 3 10: external device failure input 11: external reset input 12: free stop input 13: external stop-running order 14: stop DC braking input command DB 15: inverter run banned 16: frequency increasing control (UP) 17: frequency degression control (DOWN) 18: Acc/Dec ban command 19: three-line run control 20: closed-loop ineffective 21: PLC ineffective 22: simple PLC pause control 23: PLC stop status reset 24: frequency provision channel option 1 25: frequency provision channel option 2 26: frequency provision channel option 3 27: frequency switched to CCI 28: command switched to terminal 29: run command channel option 1 30: run command channel option 2 31: run command channel option 3 32: traverse jump-in 33: external interruption input 34: interior counter reset end 35: interior counter triggering end 36: interior timer reset end 37: interior timer triggering end 38: reserved	1	0	×
F5.01	Input terminal X2 function selection	Same as above			×
F5.02	Input terminal X3 function selection	Same as above			×
F5.03	reserved				
F5.04	reserved				
F5.05	reserved				
F5.06	reserved				

F5.07	reserved				
F5.08	FWD/REV run mode selection	0: double-line control mode 1 1: double-line control mode 2 2: three-line control mode 1 3: three-line control mode 2	1	0	×
F5.09	UP/DOWN velocity	0.01—99.99Hz/s	0.01Hz/s	1.00Hz/s	○
F5.10	Reserved				
F5.11	reserved				
F5.12	reserved				
F5.13	reserved				
F5.14	Frequency arriving (FAR) checkout scope	0.00—50.00Hz	0.01Hz	5.00Hz	○
F5.15	FDT1 (frequency level) electric level	0.00—high limit frequency	0.01Hz	10.00Hz	○
F5.16	FDT1 lag	0.00—50.00Hz	0.01Hz	1.00Hz	○
F5.17	Reserved				
F5.18	Analog output (AO) gain	0.00—2.00	0.01	1.00	○
F5.19	Analog output (AO) offset	0.00—10.00V	0.01	0.00	○
F5.20	reserved				
F5.21	reserved				
F5.22	reserved				
F5.23	reserved				
F5.24	reserved				
F5.25	Set interior counting value reaches provision	0—9999	1	0	○
F5.26	Specified interior counting value reaches provision	0—9999	1	0	○
F5.27	Interior timer setting	0.1—6000.0s	0.1	60.0	○

F6—traverse special function parameter group

Function code	name	Set range	unit	Factory default	modification
F6.00 ~ F6.07	Reversed				

F7—frequency provision function parameter group

Function code	name	Set range	unit	Factory default	modification
F7.00	VCI min. provision	0.00—F7.02	0.01V	0.00V	○
F7.01	VCI min. provision corresponding freq.	0.00—high limit frequency	0.01Hz	0.00Hz	○

F7.02	VCI max. provision	0.00—10.00V	0.01V	9.90V	○
F7.03	VCI max. provision corresponding freq.	0.00—high limit frequency	001Hz	50.00Hz	○
F7.04 ~ F7.17	Reversed				

F8—motor and vector control parameter group

Function code	name	Set range	unit	Factory default	modification
F8.00	reserved				
F8.01	Motor rated voltage	1—480V	1V	Depend on device type	×
F8.02	Motor rated current	0.1—999.9A	0.1A	Depend on device type	×
F8.03	Motor rated frequency	1.00—400.00Hz	0.01Hz	Depend on device type	×
F8.04	Motor rated speed	1—9999r/min	1r/min	Depend on device type	×
F8.05	Motor pole	2-14	2	Depend on device type	×
F8.06	Motor rated power	0.1—999.9KW	0.1	Depend on device type	×
F8.07	reserved				
F8.08	reserved				
F8.09	reserved				
F8.10	reserved				
F8.11	reserved				
F8.12	reserved				
F8.13	reserved				
F8.14	reserved				
F8.15	reserved				
F8.16	Frequency display offset	0.00Hz-2.00Hz	0.01Hz	0.20Hz	○
F8.17	reserved				

F9—protection correlative function parameter group

Function code	name	Set range	unit	Factory default	modification
F9.00	reserved				
F9.01	Failure self-renew times	0—10 0 shows no automatic reset function Remark: no automatic reset function for overload and overheating	1	0	×
F9.02	Failure self-renew interval	0.5—20.0S	0.1S	5.0S	×
F9.03	Motor overload protection mode selection	0: no action 1: inverter close off output	1	1	×

F9.04	Motor overload protection coefficient	20.0-120.0 (%)	0.1(%)	100.0(%)	×
F9.05	Overload warning alarm checkout level	20—200 (%)	1(%)	130(%)	○
F9.06	Overload warning Alarm Delay time	0.0—20.0s	0.1s	5.0s	○
F9.07	Overvoltage stall selection	0: ban 1: allow	1	1	×
F9.08	Overvoltage stall point	120-150(%)	1(%)	140(%)	○
F9.09	Reversed				
F9.10	Reversed				
F9.11	Reversed				

Fd –failure record function parameter group

Function code	name	Set range	unit	Factory default	modification
Fd.00	Previous one time failure record	Previous one time failure record	1	0	*
Fd.01	Previous two time failure record	Previous two time failure record	1	0	*
Fd.02	Previous three time failure record	Previous three time failure record	1	0	*
Fd.03	Previous four time failure record	Previous four time failure record	1	0	*
Fd.04	Previous five time failure record	Previous five time failure record	1	0	*
Fd.05	Previous six time failure record	Previous six time failure record	1	0	*
Fd.06	Set freq. of previous failure	Set freq. of previous failure	0.01Hz	0	*
Fd.07	output freq. of previous failure	output freq. of previous failure	0.01Hz	0	*
Fd.08	output current of previous failure	output current of previous failure	0.1A	0	*
Fd.09	output voltage of previous failure	output voltage of previous failure	1V	0	*
Fd.10	DC bus-bar voltage of previous failure	DC bus-bar voltage of previous failure	1V	0	*
Fd.11	Load motor speed of previous failure	Load motor speed of previous failure	1(r/m)	0	*
Fd.12	Module temperature of previous failure	Module temperature of previous failure	1℃	0	*
Fd.13	Input terminal status of previous failure	Input terminal status of previous failure		0	*
Fd.14	Accumulative run time of previous failure	Accumulative run time of previous failure		0	*

FF –password and manufacturer function parameter group					
Function code	name	Set range	unit	Factory default	modification
FF.00	User password	0000—9999	1	0000	×
FF.01	Manufacturer password	0000—9999	1	0000	×
FF.02 FF.0X	Manufacturer's special parameter				

C –supervision function parameter group					
Function code	name	Set range	unit	Factory default	modification
C-00	Set frequency	Current set frequency	0.01HZ		
C-01	Output freq.	Current output freq.	0.01HZ		*
C-02	Output current	Virtual value of current output current	0.1A		*
C-03	Output voltage	Virtual value of current output voltage	1V		*
C-04	DC bus-bar voltage	Current DC bus-bar voltage	1V		*
C-05	Load motor speed	Product of output frequency and load motor speed emendation factor	1(r/m)		*
C-06	Module temperature	IGBT heat sink temperature	1℃		*
C-07	Run time	Inverter electrification run time	1h		*
C-08	accumulative run time	Inverter accumulative run time	1h		*
C-09	Input terminal status	Switch value input terminal status	— —		*
C-10	output terminal status	Switch value output terminal status	— —		*
C-11	Analog input VCI	Analog input value of VCI	V		*
C-12	Analog input YCI	Analog input value of YCI	V		*
C-13	Reserved				
C-14	Reversed				

4 Troubleshooting





4.1 Failure and countermeasure

Possible failure types in EDS780 are shown in Table 4-1 and failure code is from E001 to E023. Some failure code is reserved for intelligent automatic diagnosis function which will be executed continuously in future. When failure takes place in the inverter, the user should check according to note of this table firstly and record failure phenomena detailedly. Please contact our after-sale service and technical support Department or agent in your local place when technical service is needed.

Table 4-1 failure type and the countermeasure

failure code	failure type	possible reason	countermeasure
E001	overcurrent during accelerating process	Accelerating time is too short	Prolong accelerating time
		Improper V/F curve	Adjust V/F curve setting, adjust manual torque boost or change to automatic torque boost
		Restart rotating motor	Set speed checking restart function
		Low power source voltage	Check input power supply
		Too small power of the inverter	Choose inverter with high-power
E002	overcurrent during decelerating process	Decelerating time is too short	Prolong decelerating time
		Have potential energy load or big inertia load	Increase braking power of external energy consumption braking subassembly
		Power of inverter is a bit small	Choose inverter with high-power
E003	overcurrent during constant speed process	Load change suddenly or have unwonted phenomena	Check or reduce break of the load
		Accel/Decel time is set to too short	Prolong accelerating decelerating time properly
		low power source voltage	Check input power supply
		Power of inverter is a bit small	Choose inverter with high-power
E004	overvoltage during accelerating process	Unwonted input voltage	Check input power supply
		Accel time is set to too short	Prolong accelerating time properly
		Restart rotating motor	Set speed checking restart function
E005	overvoltage during decelerating process	Decelerating time is too short	Prolong decelerating time
		Have potential energy load or big inertia load	Increase braking power of external energy consumption braking subassembly
E006	Overvoltage during constant speed process	Unwonted input voltage	Check input power supply
		Accel/Decel time is set to too short	Prolong accelerating decelerating time properly
		Input voltage change abnormally	Assemble reactor

		Load inertia is a bit big	Use energy consumption subassembly
E007	control power supply overvoltage	Unwanted input voltage	Check input power supply or look for service
E008	Inverter overload	Accel time is set to too short	Prolong accelerating time
		DC injection braking is too big	Reduce DC injection braking current, prolong braking time
		improper V/F curve	Adjust V/F curve and torque boost
		Restart rotating motor	Set speed checking restart function
		power source voltage is too low	check power source voltage
		Load is too big	Choose inverter with high-power
E009	Motor overload	improper V/F curve	Adjust V/F curve and torque boost
		power source voltage is too low	check power source voltage
		General motor run at low speed with big load	Can choose frequency conversion motor for long time low speed run
		motor overload protection factor set incorrectly	to set motor overload protection factor correctly
		motor blocked up or load change too suddenly and quickly	Check the load
E010	inverter over heating	Air-path blocked	To clear air-path or improve ventilation condition
		Ambient temperature is too high	Improve ventilation condition, lower carrier frequency
		Run with large load long time	Use fan outside to radiate
E011	reserved		
E012	reserved		
E013	Inverting module protection	Transient overcurrent of the inverter	Refer to countermeasure for overcurrent
		phase to phase short circuit or earthing short circuit of output 3 phase	wiring again
		Air-path blocked or fan damaged	To clear air-path or replace the fan
		Ambient temperature is too high	Lower ambient temperature
		Connecting wire or insert on control board loose	Check and connect the wire again
		Unwanted current wave caused by missing output phase etc.	Check wiring
		Assistant power supply damaged and drive voltage lacking	Look for service from manufacturer or agent
		Unwanted control board	Look for service from manufacturer or agent

E014	external device failure	use sudden stop  key in non-keypad run mode	Look up operation mode
		Use sudden stopkey  under condition of stall	Set running parameter correctly
		Sudden stop terminal for external failure closed	Open external failure terminal after external failure is settled
E015	reserved		
E016	RS485 communication failure	Baud rate set improperly	set Baud rate properly
		Serial port communication error	press  key to reset, look for service
		Failure warning parameter set improperly	Modify F2.16, F2.17
		Upper device doesn't work	Check if upper device work and wiring is correct
E017	reserved		
E018	reserved		
E019	Under voltage	Under voltage	check spot input voltage
E020	System disturbance	Serious disturbance	Reset by pressing  key or add mains filter at power supply input side
		CPU read and write wrongly	Reset by the key-press, look for service
E021	reserved		
E022	reserved		
E023	E ² PROM read and write wrongly	Mistake take place when read or write control parameter	Reset by pressing  for service from manufacturer or agent
P.OFF	Under voltage	Under voltage	check spot input voltage

4.2 Failure record lookup

This series inverter can record latest 6 failure code and inverter run parameter of the last failure, to search these informations can redound to finding out reason of the failure.

Failure information is all stored in Fd group parameter, please enter into Fd group parameter to see about information by referring to keypad operation method.

Code	Content	Code	Content
Fd.00	previous one failure record	Fd.08	output current at previous failure
Fd.01	previous two failure record	Fd.09	output volt. at previous failure
Fd.02	previous three failure record	Fd.10	DC bus-bar vlot. at previous failure
Fd.03	previous four failure record	Fd.11	load motor speed at previous failure
Fd.04	previous five failure record	Fd.12	module temp. at previous failure
Fd.05	previous six failure record	Fd.13	input end state at previous failure
Fd.06	set freq. at previous failure	Fd.14	Accu. runtime at previous failure
Fd.07	output freq. at previous failure	—	—

5 Maintenance

5.1 Routine maintenance

You must assemble and operate it according to demand listed in this 《service manual》 strictly when you use inverter. During run state, temperature, humidity, vibration and aging parts may affect it. To avoid this, it is recommended to perform routine inspections.

Table 5-1 Daily inspection items

period		Inspection item	Inspection content	Criterion
daily	periodic			
√		Run state parameter	(1)output current	(1)within range of rated value
			(2)output voltage	(2)within range of rated value
			(3)inside temp.	(3)temp. increment < 35℃
√		Cooling system	(1)installing ambient	(1)good ventilation, unblocked air-path
√		Motor	(1)heating	(1)no abnormality
			(2)noise	(2)even
	√	Inverter	(1) vibration, heating	(1)vibration balanced, proper wind temp.
			(2)noise	(2) without abnormal sound
			(3)fixation of lead, terminal	(3)fixed screw don't loose
√		Run ambient	(1)temperature, humidity	(1)-10℃~+40℃ 40℃~50℃used in lower volume or execute compulsory heat dissipating
			(2)dust, water and leakage	(2)no water leakage imprint, no dust
			(3)gas	(3)no peculiar smell

Recommend to inspect with following instrument:

Input voltage: electric voltmeter; output voltage: rectifying voltmeter; input output current: pincers ammeter.

5.2 Inspection and replacement of damageable parts

Some component parts in the inverter will be abraded or bear descending performance for long-term usage, to assure that the inverter can run stably and reliably, it is recommended to perform defending maintenance and replace corresponding parts if necessary.

(1) filter electrolyte capacitance

When frequent-changing load causes increasing pulsant current and aging electrolyte under high ambient temperature, the electrolyte capacitance may be damaged and here should replace it.

5.3 Repair guarantee

(1) Within 18 months from purchasing date, if failure caused by inverter itself takes place under normal conservation and usage, we will provide free repair service.

(2) We will take some upkeep if one of following situations takes place within period of repair guarantee.

a. If did not use the inverter according to 《service manual》 strictly or did not use it under ambient demanded in 《service manual》 , which cause failure.

b. Failure caused by applying the inverter to non-normal function;

c. Failure caused by self-repair, refit which is not already allowed;

d. Damage caused by bad keeping, falling down from high place or other extrinsic factor after purchasing the inverter;

e. Failure caused by natural disaster or its reason such as unwonted voltage, thunderbolt, water fog, fire, salt corroding, gas corroding, earthquake and storm etc.;

f. Make bold to tear up product logo (such as: nameplate etc.); Body serial number don't accord with that in repair guarantee card.

(3) We calculate service fee based on actual cost, which is subject to contract if any.

(4) You can contact the agent and also our company directly if you have questions.

After repair guarantee period, we shall also provide lifetime charged repair service for our products.



note

Our company will also provide lifetime repair service with fee for inverter which is not within period of repair guarantee.

5.4 Storage

The user must pay attention to following points for temporary storage and long-term storage after purchasing the inverter:

(1) Avoid storing the inverter in high temperature, moist place and place of dust, metal powder and assure good ventilation.

(2) Longtime storage will cause electrolyte capacitance of low quality, so must assure that it's electrified for one time within 2 years and electrification time is not shorter than 5 hours and input voltage must be increased to rated value gradually by voltage adjustor.

ENC Shenzhen Encom Electric Technologies CO., LTD.

Address: 5-6F, Bldg.4, Minqi Technology Park, Lishan Rd.,
Nanshan Area, Shenzhen 518055, China

Website: www.encvfd.com

E-mail: encvfd@encvfd.com
encvfd@enc.net.cn

Tel: +86-755-26984485

Fax: +86-755-26985120